

# AFC-100

## Fire Alarm Installation Manual



Potter Electric Signal Company, LLC  
St. Louis, MO

Customer Service: (866) 240-1870 • Technical Support: (866) 956-1211 • Fax: (314) 595-6999  
For listing information visit our website [www.pottersignal.com](http://www.pottersignal.com)

Document 5403648-Rev. F  
12/20

# 1. Installation Wiring Documents

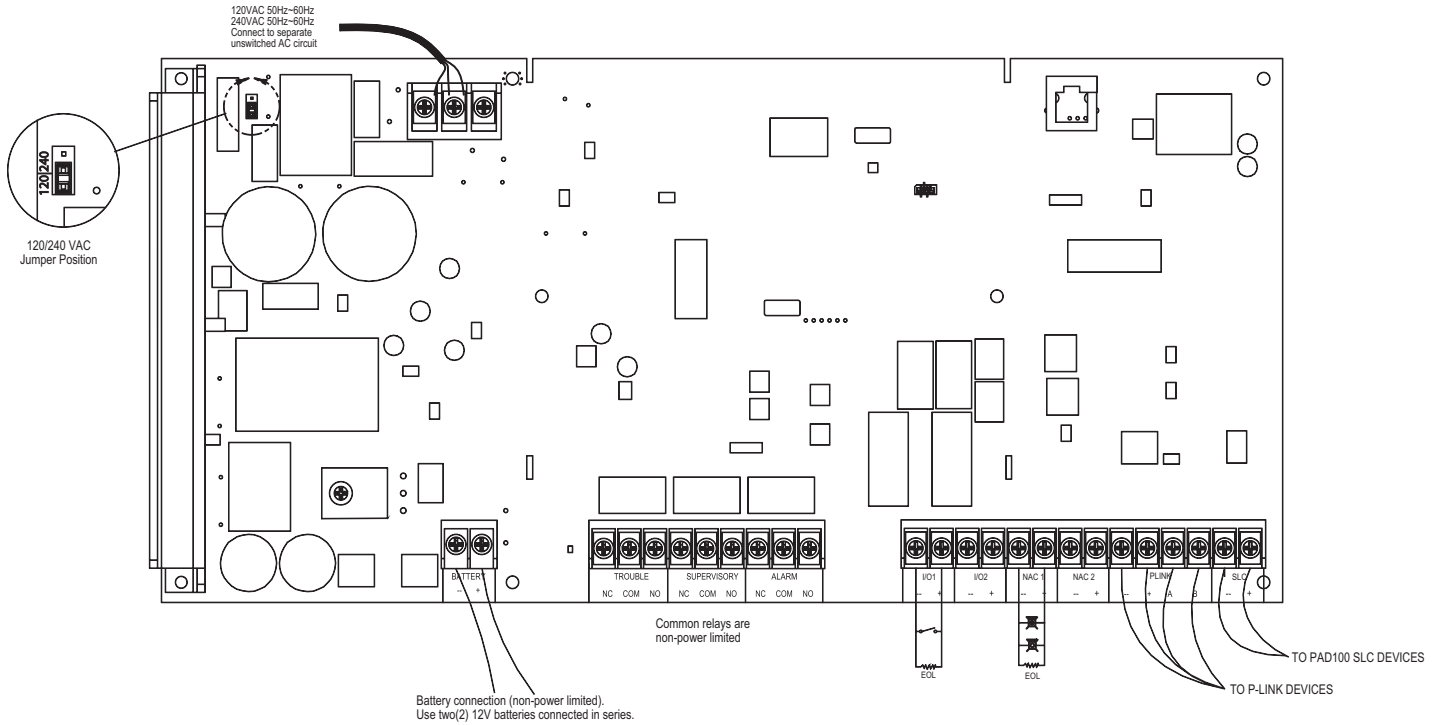

DWG #640-1

Figure 1. AFC-100 Addressable Fire Panel Wiring Diagram

Type of Circuit	Voltage Type	Power Type
AC Connection	High Voltage	Non-Power Limited
Battery Connection	Low Voltage	Non-Power Limited
Trouble Relay	High Voltage	Non-Power Limited
Supervisory Relay	High Voltage	Non-Power Limited
Alarm Relay	High Voltage	Non-Power Limited
I/O Circuits	Low Voltage	Power Limited
Notification Device Circuits (NACs)	Low Voltage	Power Limited
P-Link RS-485 Connections	Low Voltage	Power Limited
Signaling Line Circuit	Low Voltage	Power Limited
Phone Line – DACT	High Voltage	Power Limited

## Main Supply Circuit

The AC terminals are located in the upper left hand portion of the main board. The main board supervises the main AC power and provides indication that the AC power is absent.

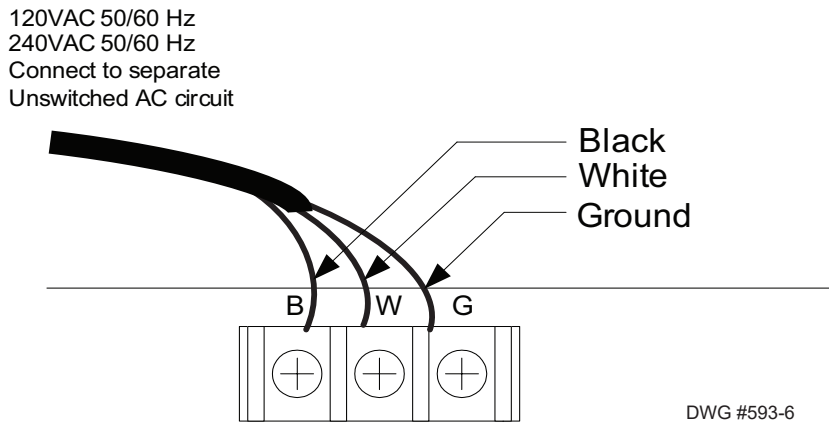

Figure 2. Main Supply Circuit

The terminals are rated at 120 VAC/240 VAC 50/60 Hertz and are marked so accordingly on the board. The earth ground connection is marked as “G” and is the furthest connection from the line voltage connection.

The AC input power ratings:

Maximum of 5A at the nominal 120 VAC rating.

Maximum of 3A at the nominal 240 VAC rating.

## Rechargeable Battery Circuit

The battery charging circuit is provided on the main panel in the lower left portion of the board. Terminal connections are provided to connect wire leads for battery connection. The battery must be a recognized or listed sealed lead acid battery or equivalent.

The battery charging voltage is approximately 27.3 VDC and the circuit is supervised. The battery circuit is protected with a non-replaceable 7 amp poly switch located on the main circuit board. The maximum battery charging current is 1.0 amp DC.

The battery circuit is rated for 8 to 55 AH batteries and the cabinet will house up to two 18 AH batteries. The batteries will operate the panel for at least 24 hours and 5 minutes of alarm. In order to determine the minimum size batteries for standby and alarm times desired, the installer must complete a battery calculation work sheet in order to determine the minimum battery size for a particular application. For reference, the battery calculation work sheet is attached as Appendix A. Complete standby battery calculations must be completed to ensure adequate battery sizes are provided.

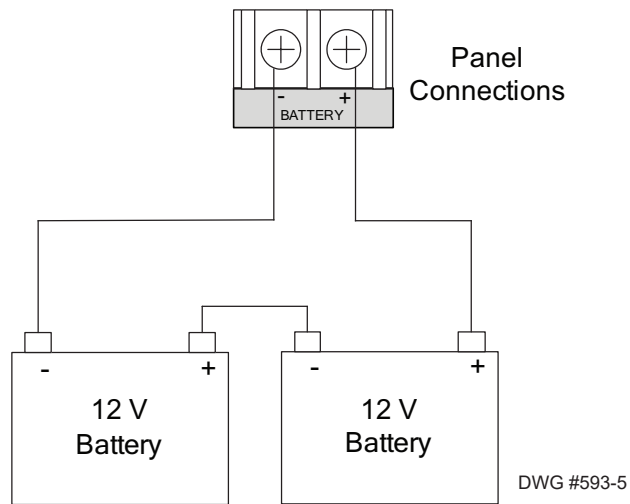

Figure 3. Battery Circuit Connections

### Separation of Circuits - Power Limited, Non-Power Limited, High Voltage Wiring

The main AC power connection is considered high-voltage and non-power limited. The phone line connections to the DACT are high-voltage – power limited. Battery conductors, and the alarm, supervisory, and trouble relays are non-power limited. All remaining circuits are low-voltage, power limited connections.

Proper separation must be maintained between the circuits listed above. All separations in the different wiring must be maintained by at least 0.25 inches and the wire insulation must be for the higher voltage.

In the panel there are sufficient knock outs located around the periphery of the cabinet to allow the installer to maintain power limited and non-power limited connections. The main AC power connection should be made on the left side or top left of the cabinet. The DACT wiring connections should be made along the top right side of the cabinet.

### Notification Appliance Circuits (NACs)

The panel is equipped with two NAC circuits and each are rated for a continuous 3 amps at 24 VDC. The outputs are supervised and regulated. The NACs reverse polarity upon activation and the board and illustrations are marked accordingly.

The panel can be programmable to allow for addition of a CA-6075 Class-A Expander. This expander allows for Class A operation of the NACs. Each Class A circuit is rated for a continuous 3 amps at 24 VDC. The outputs are supervised and regulated.

NAC circuits are power limited and the type of output is selectable. The NACs may be configured for strobe synchronization with AMSECO, Wheelock, Gentex, or System Sensor strobe devices as shown compatible in this document and the installation instructions.

The maximum impedance is a function of the load being applied to the circuit. In order to calculate the maximum impedance as follows:

$$(\text{Alarm Current of Notification Appliances}) \times (\text{Wire Resistance}) < 3 \text{ volts.}$$

The NAC circuits may be configured for Class A or Class B.

The panel has ground fault detection on the NAC circuits. The impedance to ground for ground fault detection is 0 ohms.

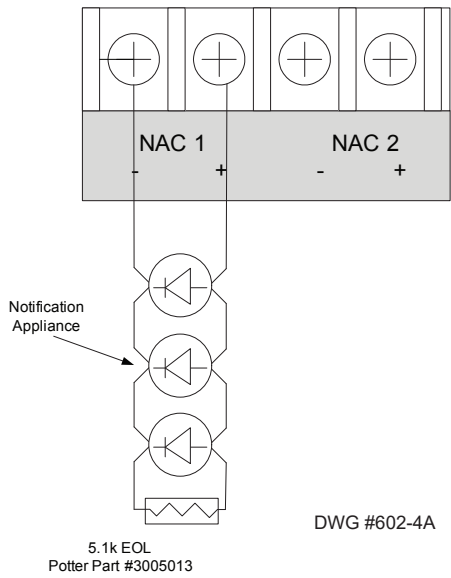

Figure 4. Class B NAC Wiring

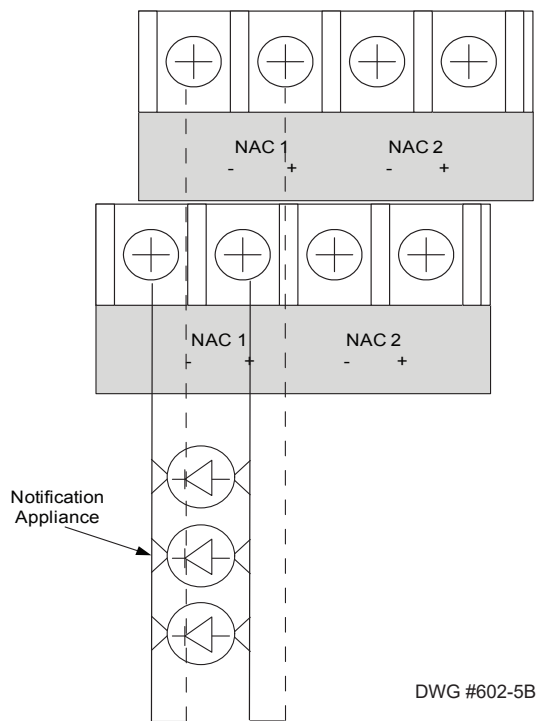

Figure 5. Class A NAC Wiring Requires CA-6075

The end of line resistor is a 5.1K ohm resistor. The resistor assembly has been evaluated in past projects and is a standard in the Potter panel product line. The Potter part number for the listed end of line assembly is 3005013 EOL Resistor Assembly.

## I/O Circuits

The panel is equipped with two I/O circuits. The I/O circuits can be configured as either an input or an output. The I/O circuits can be used in Class B mode only.

### I/O Circuit as Inputs

As inputs, the I/O circuits are used as a dry contact monitoring inputs, and are power limited and supervised.

- Maximum wiring resistance = 100 ohms.
- Maximum wiring capacitance = 1 uF.
- Maximum wire length = 10,000 feet.
- Maximum IDC voltage = 24 VDC
- Maximum IDC current = 15 ma

The circuit can be configured for the same selection of contact input functions as the SLC MCM and SCM modules.

### I/O Circuit as Outputs (NAC)

As outputs, each of the I/O circuits is rated for 1 amp continuous current at 24 VDC. The outputs are supervised and regulated. The circuits reverse polarity upon activation and the board and illustrations are marked accordingly.

The circuit is power limited and the type of output is selectable. I/O circuits may be configured for strobe synchronization with AMSECO, Wheelock, Gentex, or System Sensor strobe devices as shown compatible in this document and the installation instructions.

The maximum impedance is a function of the load being applied to the circuit. In order to calculate the maximum impedance as follows:

$$(\text{Alarm Current of Notification Appliances}) \times (\text{Wire Resistance}) < 3 \text{ volts.}$$

The panels have ground fault detection on the I/O circuits. The impedance to ground for ground fault detection is 0 ohms.

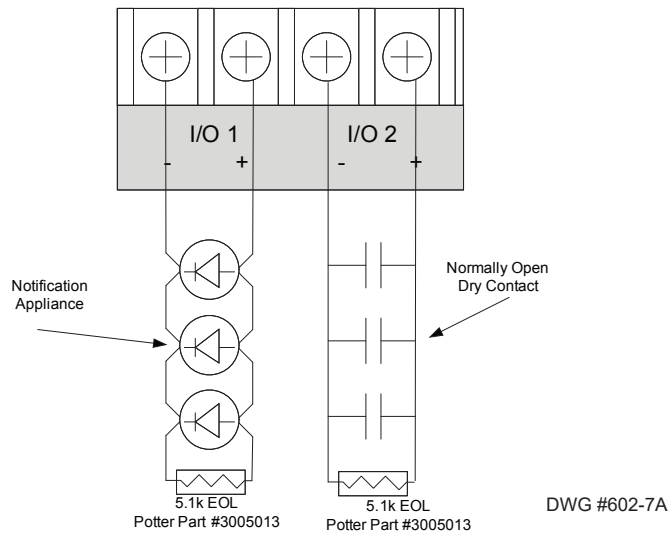

Figure 6. I/O Circuits Shown as Class B NAC / Dry Contact Input

The end of line resistor is a 5.1K ohm resistor. The resistor assembly has been evaluated in past projects and is a standard in the Potter panel product line. The Potter part number for the listed end of line assembly is 3005013 EOL Resistor Assembly.

## Signaling Line Circuit (SLC)

The panel is equipped with one built-in SLC loop supporting a maximum of 100 PAD protocol devices. One PAD100-SLCE or one SLCE-127 can be added to the system to support 100 devices instead of using the built-in SLC loop. The PAD100-SLCE supports the PAD protocol, and the SLCE-127 supports the Nohmi protocol.

The addressable points may be any combination of smoke sensors, heat detectors, input modules or output modules.

The SLC provides power and communication to each of the sensors and modules connected. The SLC is fully supervised in that the communication signal is sent and must be received from each device. The entire loop is polled approximately every 4 seconds.

The voltage range for the SLC is 22-24 VDC. The power is a constant regulated connection with a maximum line resistance of 50 ohms. The SLC has a maximum loop capacitance of 0.5 micro-farads. The maximum PAD100-SLCE fully loaded loop current is 90.61 mA.

The panel has ground fault detection on the SLC circuits and addressable devices. The impedance to ground for ground fault detection is 0 ohms.

The SLC may be configured and installed as a Class A, Class X or Class B.

If the Nohmi protocol SCI short circuit isolators are installed, a total of 8 devices must be deducted from the total number of devices for each isolator installed.

All SLC wiring is low voltage and power limited.

### SLC Address Programming

Addresses for all PAD protocol devices are assigned via a dipswitch on the device.

Addresses for the Nohmi protocol devices are assigned by using the hand-held programmer (part # FZAW004-P/3610053).

### *SLC Class X Wiring*

For the PAD protocol, Class X requires a PAD100-IB to be installed for each sensor and/or PAD100-IM to be installed on each side of each module. The maximum wiring resistance between a PAD100-IB/PAD100-IM and another PAD100-IB/PAD100-IM shall be less than 10 ohms and the total resistance must be below 50 ohms. The maximum wiring resistance shall be calculated based on 0.1 ohm per PAD100-IB/PAD100-IM.

For the Nohmi protocol, Class X requires one AIB to be installed for each sensor and/or SCI to be installed on each side of each module. The maximum wiring resistance between an AIB/SCI shall be less than 10 ohms and the total resistance must be below 50 ohms. The maximum wiring resistance shall be calculated based on 0.1 ohm per ABI/SCI.

**Note:** Class X requires a close nipple or conduit connection to every module or sensor for both PAD and Nohmi protocols.

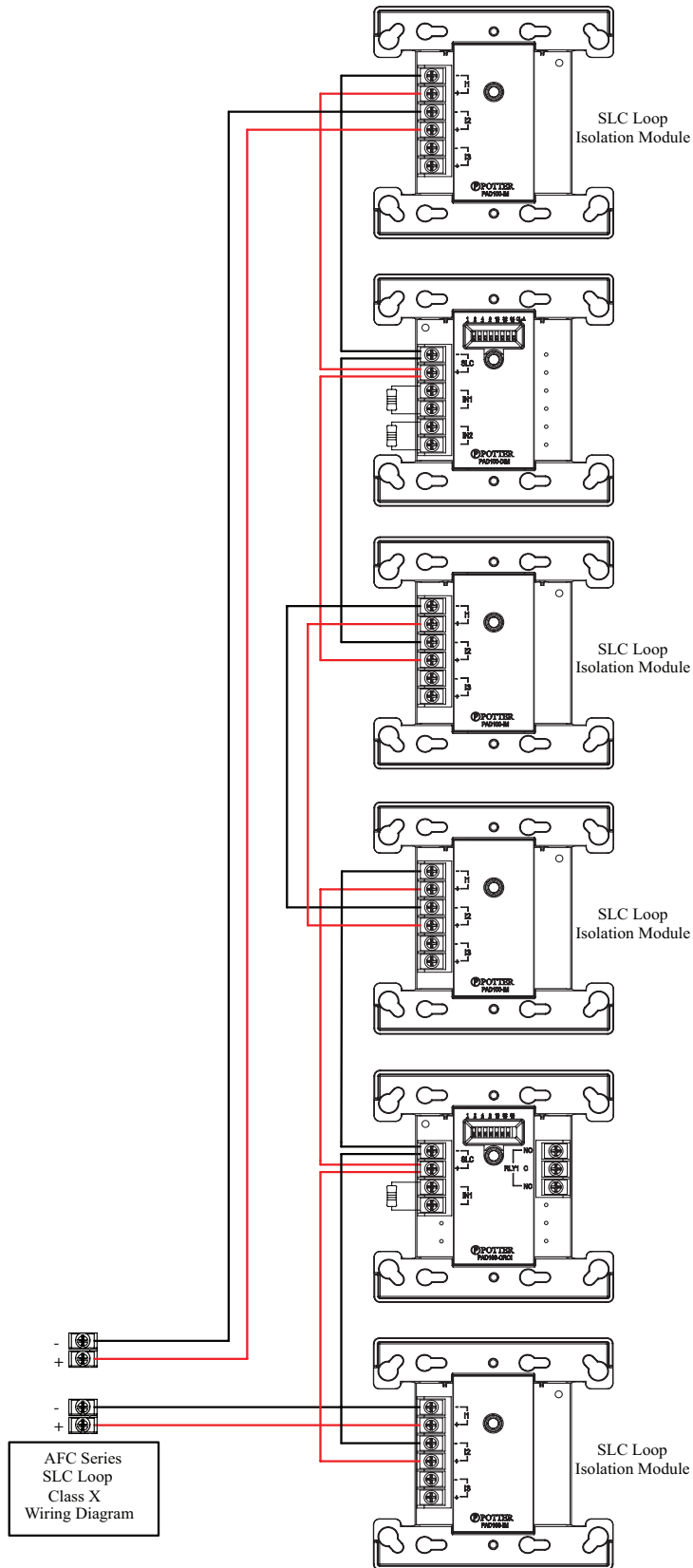
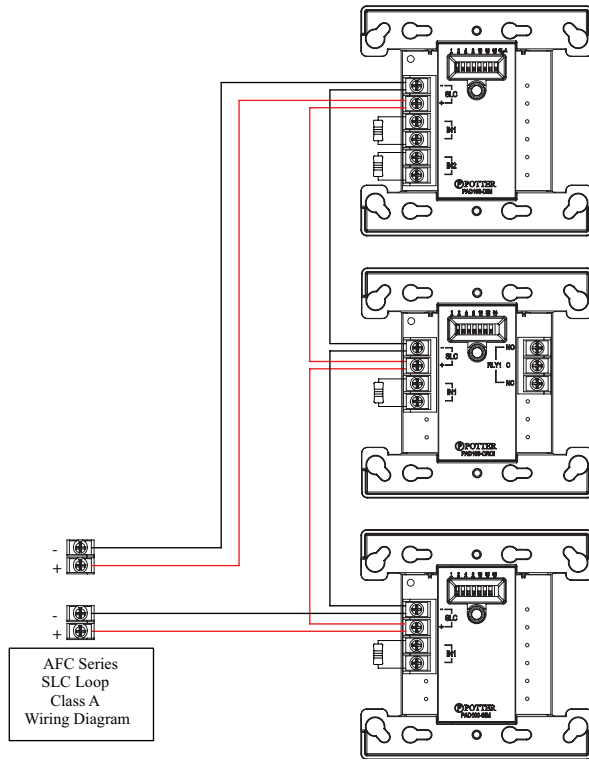

Figure 7. PAD Protocol Class X Showing PAD100-IMs Installed





DWG #641-3

Figure 8. PAD Protocol Example of SLC as Class A

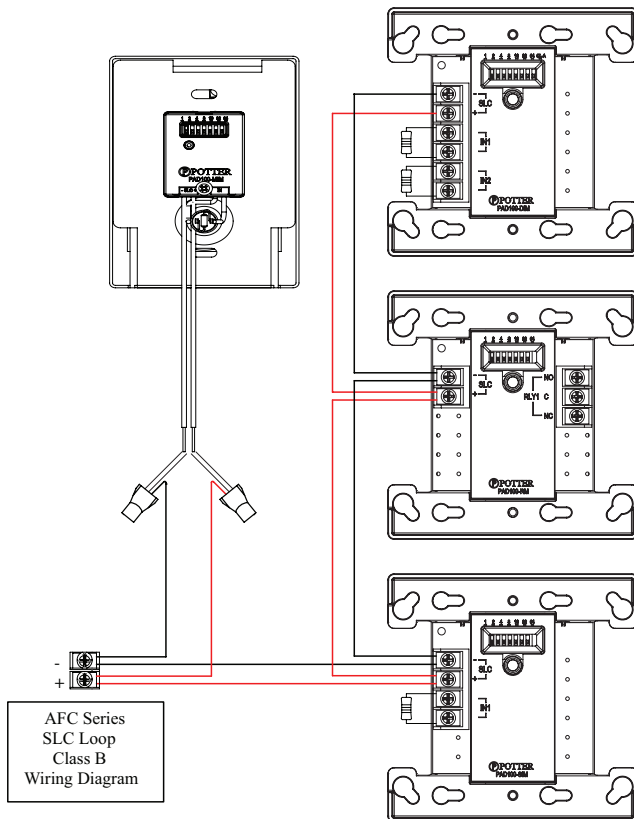

DWG #641-4

Figure 9. PAD Protocol Example of SLC as Class B

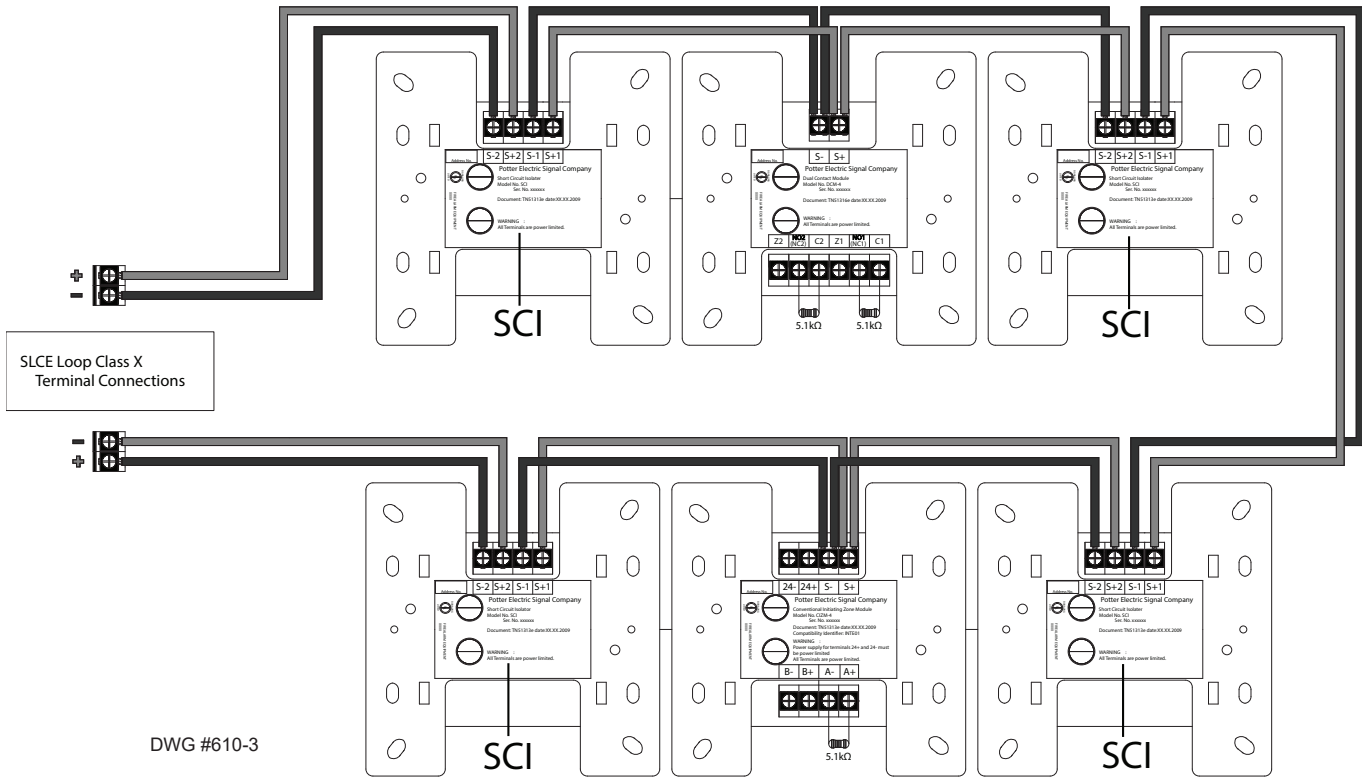

Figure 10. Nohmi Protocol Example of SLC Wired Class X

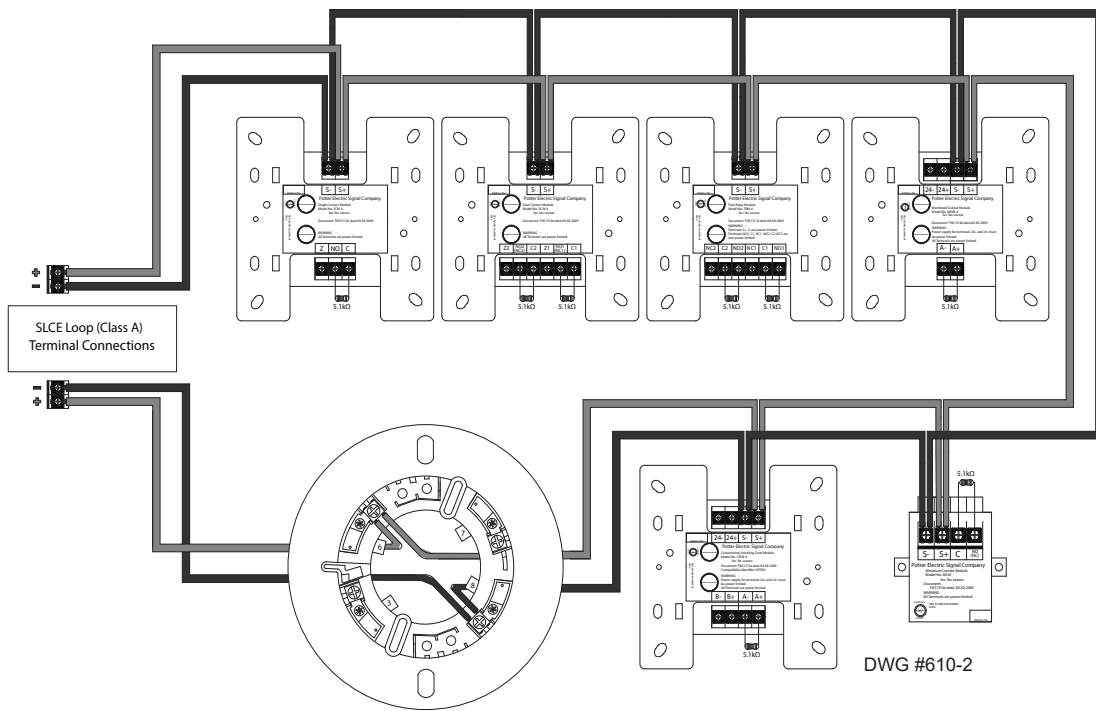

Figure 11. Nohmi Protocol Example of SLC Wired Class A

For Class B, installation of the CA-6075 is not required.

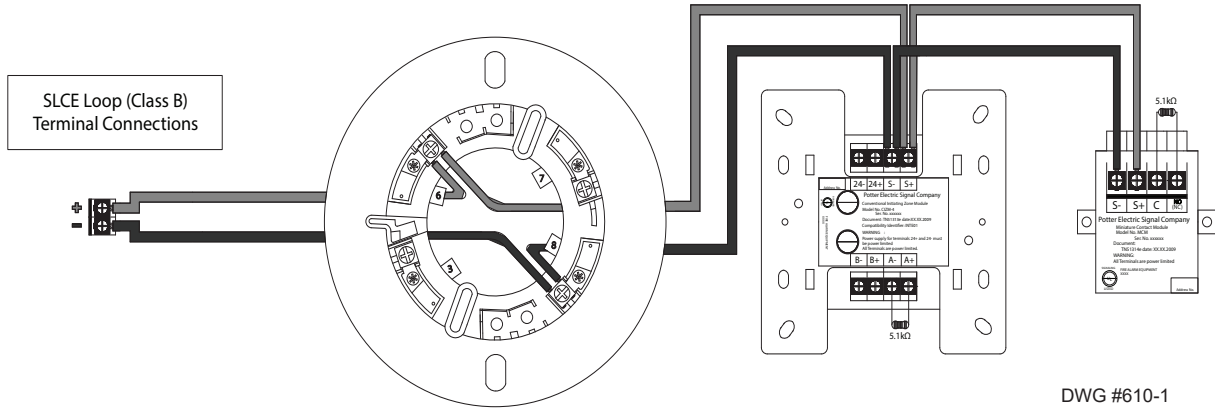

Figure 12. Nohmi Protocol Example of SLC as Class B

### P-Link Expansion Bus Circuits

All expansion devices are supervised via the RS-485 connection. Wiring is fully supervised and power limited. Any connection to ground of 0 ohms will be annunciated as a ground fault.

**P-Link Current** = 1 Amp

**P-Link Voltage** = 20.0 VDC - 27.3 VDC

**Maximum wire length** = 6,500 feet.

**Maximum wire resistance** = Maximum wiring resistance is based on load.

Calculate using the following equation

$$(\text{Total P-Link Alarm Current}) \times (\text{Wire Resistance}) < 6 \text{ volts.}$$

The worst case P-Link current draw cannot exceed the 1 amp. P-Link wiring gauges and lengths are calculated using the worst-case current draw values from the table below. The worst case current draw numbers are used only for wiring calculations, refer to the battery calculation worksheet for normal standby and alarm currents.

P-Link Accessory	Worst Case current draw (ma)
PAD100-SLCE (PAD Protocol)	200
SLCE-127 (Nohmi Protocol)	200
PSN-1000/PSN-1000(E)	10
RA-6075R	25
RA-6500R / RA-6500F	25
UD-1000/UD-2000	25
LED-16/LED-16F	25
DRV-50	25
RLY-5	35
FIB-1000	30
FCB-1000	25
SPG-1000	40
MC-1000	10
IDC-6	20
NCE-1000	50
NCF-1000	95

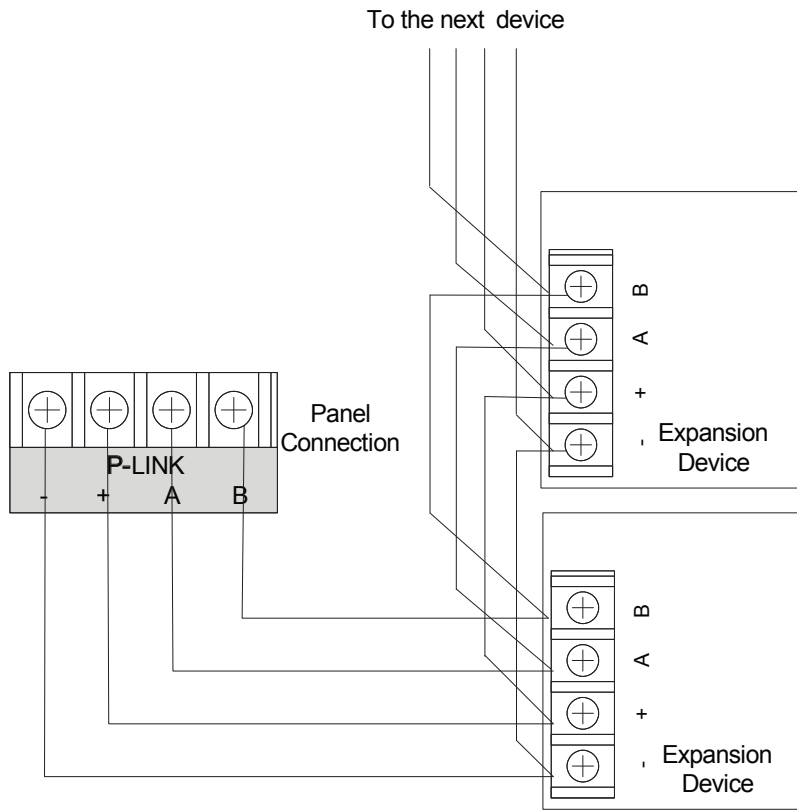

DWG #602-11A  
 Figure 13. Example of P-Link Class B Wiring

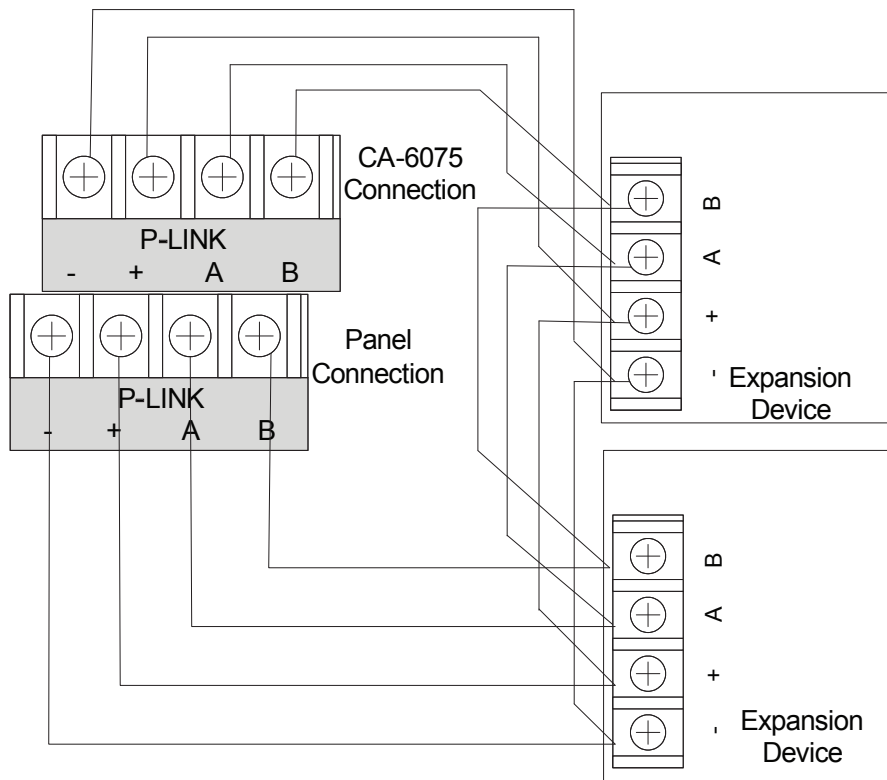

DWG #602-12A  
 Figure 14. Example of P-Link Class A Wiring Requiring a CA-6075

The panels can be programmed to support the following P-Link devices:

**PAD100-SLCE/SLCE-127**

The panels can be programmed to support one PAD100-SLCE (PAD protocol) or one SLCE-127 (Nohmi protocol) loop expander if the built-in SLC loop is disabled. The expansion cards support up to 100 addressable points. The expansion cards support both Class B and Class A wiring.

**Remote Annunciator/Keypad Circuits (RA-6500R, RA-6500F, RA-6075R)**

A maximum of 31 annunciators in any combination may be connected to the main fire control panel. The RA-6500R and RA-6500F provide a 4x40 character LCD display, along with standard function and numeric keys. The RA-6075R provides a 2x16 character LCD, along with standard function and numeric keys.

**UD-1000/UD-2000**

The panel can be programmed to support the UD-1000/UD-2000 digital alarm communicator transmitter (DACT). The DACT may be enabled, disabled or bypassed depending on the mode of operation. When the DACT is disabled, the panels are not capable of transmitting any alarms off premises through the DACT.

The DACT provides for up to two phone lines for communication to a monitoring station. The DACT communicates using the SIA-DCS or Ademco Contact ID protocols. When enabled, the DACT automatically monitors each phone line or voltage and has the ability to seize the line and connect with a remote receiver. Once the communication is complete, the DACT will hang up the phone line.

The UD-1000 is provided with an RJ-11 jack for each phone line. The UD-2000 is provided with terminal blocks for each phone line connection. In order for the DACT to work properly, it must be installed on a plain old telephone service (POTS) or equivalent as deemed by the authority having jurisdiction. The DACT must be installed before any other equipment to ensure it can seize the line and disconnect any other lines.

Phone lines are high voltage and should be run in a separate conduit from other circuits. The wire conductors connecting the DACT to the phone system should be 26 AWG or larger.

**LED-16/LED-16F (LED Annunciator)**

The panel can be programmed to support up to 10 total LED-16/LED-16F and/or DRV-50 modules. Each LED-16/LED-16F can display alarm/supervisory/trouble conditions for up to 16 zones. Each LED is assigned to a zone, when that zone becomes active, the LED will illuminate. Five (5) non-programmable system LEDs are also provided, which annunciate the overall system condition (Power, Earth, Silenced, Alarm, Supervisory & Trouble).

**DRV-50 (LED Driver)**

The panel can be programmed to support up to 10 total DRV-50 and/or LED-16/LED-16F modules. The DRV-50 has 50 LED outputs that can be individually mapped to any zone. The DRV-50 also has four (4) programmable supervised dry contact inputs, and five (5) non-programmable system LED outputs, which annunciate the overall system condition (Power, Earth, Silenced, Alarm, Supervisory, & Troubles).

**RLY-5 (Relay Board)**

The panel can be programmed to support up to 31 RLY-5 modules. The RLY-5 provides 5 Form-C relay outputs which can be individually mapped to any zone. The Relays have a contact rating of 24VDC / 3.0A, 125VAC / 3A, and Power Factor of 1.0. These outputs are non-power limited and not supervised.

**Note:** If the power supply connected to the relays is power-limited, then the outputs are power limited.

**FCB-1000 (Fire Communications Bridge)**

The panels support one FCB-1000. The FCB-1000 provides a remotely-located IP connection into the panel. All IP reporting can be designated to pass through the FCB-1000 instead of through the on-board internet connection.

**FIB-1000 (Fiber Interface Bridge)**

The panels support up to 31 FIB-1000s. The FIB-1000 can be used to convert the standard 4 wire P-Link bus to/

from fiber optic cable. The FIB-1000 uses multi-mode fiber, and is capable of Class A operation.

### **SPG-1000 (Serial/Parallel Gateway)**

The panel supports up to 31 SPG-1000 modules. The SPG-1000 can be used to drive a serial and/or parallel printer.

### **MC-1000 (Multi-Connect)**

The panels support up to 31 MC-1000 modules. The MC-1000 allows multiple AFC series panels to report to the central station through a shared phone line or Internet connection.

### **PSN-1000/E (Power Supply Expander)**

The panel can be programmed to support up to 31 PSN-1000/PSN-1000(E) Power Expanders. Each power expander provides 6 NAC circuits (3A max), and 2 dry contact input circuits. The PSN-1000/PSN-1000(E) reconditions/repeats the P-Link bus that provides additional distance and power.

### **IDC-6 (Initiating Device Circuit)**

The panel supports up to 31 IDC-6 modules. Each IDC-6 provides 6 additional conventional Class B inputs or 3 Class A Inputs.

### **NCE-1000 (Network Card Ethernet)**

The panel supports up to 31 NCE-1000 and 200 per system. It is used to network the fire alarm panels using CAT5 Ethernet cable. It is fully supervised and is capable of Class B and Class A operation.

### **NCF-1000 (Network Card Fiber)**

The panel supports up to 31 NCF-1000 and 200 per system. It is used to network the fire alarm panels using fiber optic cable. The NCF-1000 allows the user to install SFP (small form-factor pluggable) modules to utilize either single mode or multi-mode fiber. It is fully supervised and is capable of both Class B and Class A operation.

## Releasing Device Circuit

The releasing circuit is fully supervised and power limited. The releasing device circuit is a NAC that is programmed to control a releasing device such as a solenoid or squib.

When the control panel is programmed for releasing, additional features are allowed specific to releasing. A PAD100-NAC (NAC) notification appliance circuit may be connected to a releasing device as well and operate as a releasing circuit. When the NAC is used for releasing, it must have a regulated power supply that has a battery back-up equal to that of the panel or greater.

The output is a constant 24 VDC, regulated output. When connected to a releasing device, the circuit is a special application circuit and listed with the devices as outlined in Section 6 of this document.

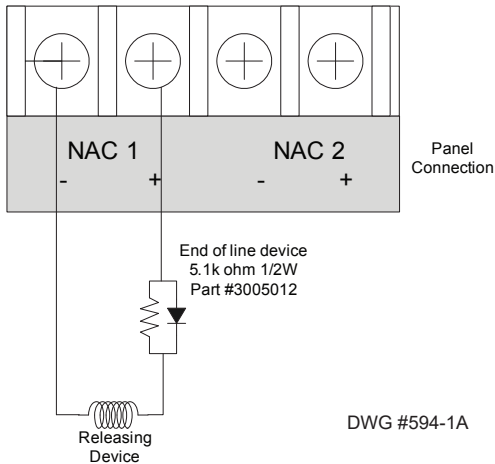

Figure 15. NAC Releasing Circuit Wiring with EOLD Assembly

The maximum current is 3 amps. The maximum line impedance is calculated using the following formula.

$$R_{max} \text{ (ohm)} = (24V - V_{min} - 0.95V) / I_{total}$$

$V_{min}$  is the lowest voltage operation of the connected devices.

$I_{total}$  is the total current of the connected devices.

When a NAC is used as a releasing circuit, the End of Line Diode (EOLD) assembly must be installed. The EOLD is Potter part number 3005012 and must be installed in accordance with the installation manual.

According to UL 10th Edition, the disabling of a releasing circuit shall be accomplished by a physical switch activated without the use of the software. When a releasing circuit is disabled a supervisory signal will be annunciated at the FACP.

## Municipal Box Connection

When programmed as a municipal box connection, the circuit power is limited, supervised for open and short circuit conditions, and provides a local energy connection.

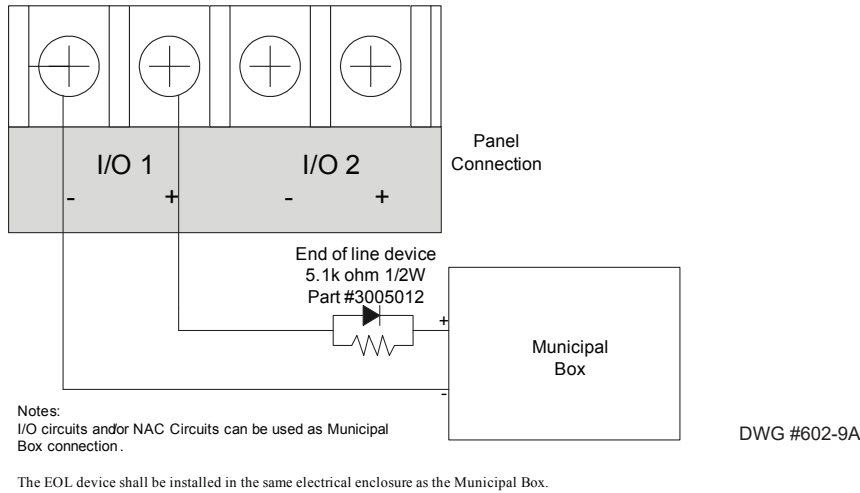

Figure 16. Municipal Box Wiring Example

Trip current = NAC1 and NAC2 = 3 Amps, I/O1 and I/O2 = 1 Amp

Max Voltage = 24 VDC

The panel has ground fault detection on municipal box connection circuits. The impedance to ground for ground fault detection is 0 ohms.

## Reverse Polarity Communication Line Circuit

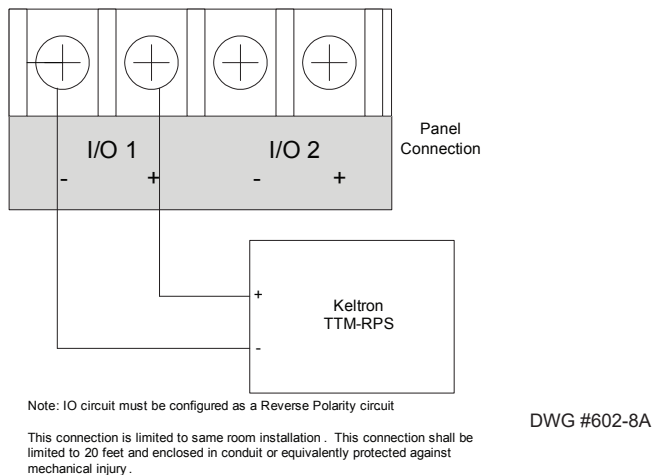

Figure 17. Example of Reverse Polarity I/O Circuit Wiring

Only the I/O circuits on the panel can be programmed as reverse polarity circuits. The short circuit current is rated at 24 VDC and 14 mA maximum.

When configured for reverse polarity, the panel will indicate alarm and trouble events to a remote site. Alarms will override trouble conditions.

The panel has ground fault detection on reverse polarity circuits. The impedance to ground for ground fault detection is 0 ohms.

The connection between the FACP and the remote device shall be limited to 20 feet and enclosed in conduit or equivalently protected against mechanical injury.



## Relay Outputs

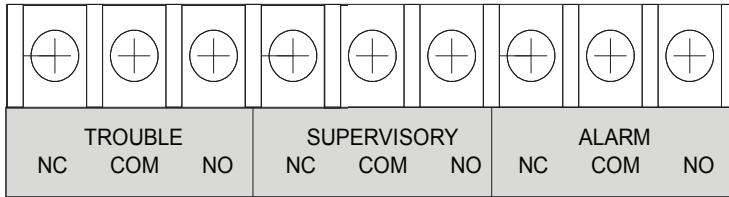

DWG #593-26

Figure 18. Panel's Dedicated Relay Outputs

The panel has three dedicated common relays. The dedicated trouble relay is a failsafe trouble relay that changes position anytime a trouble condition occurs.

The contact rating is 24VDC / 3.0A, 125VAC / 3A, Power Factor: 1.0. These outputs are non-power limited and not supervised. However, they are power-limited if the power supply to the connected devices is power-limited.

## General Wiring Information

The cabinet has various conduit knockouts located around the cabinet for ease of wire installation. In addition, this method provides a means to separate different types of circuit to reduce electrical interference, transient voltage or voltage ratings.

The enclosure requires the use of power limited and non-power limited wiring on the main board as well as within the enclosure. Power limited wiring is to remain separated from non-power limited by a minimum of 0.25 inches and all cabling should be insulated to the higher voltage.

When the panel is installed, the National Electrical Code (NEC, NFPA 70) should be followed for the proper installation and separation of power limited and non-power limited circuits. The mixing of power limited and non-power limited should be avoided. Refer to the following figure for suggested wiring routing.

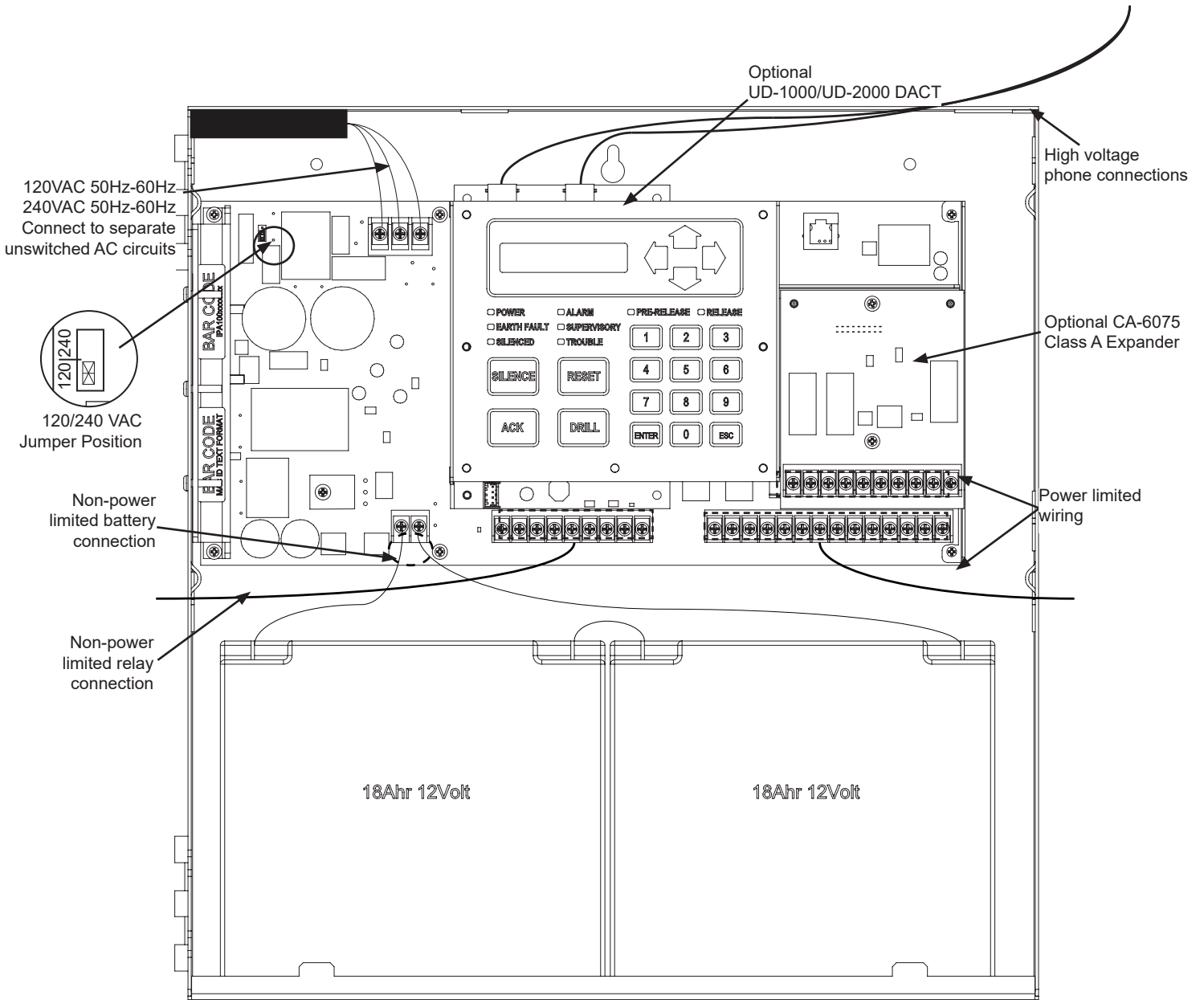

Figure 19. Example of Panel's Wire Routing

## 2. Operation

System Type:	Auxiliary Central Station (Protected Premises Unit) Proprietary (Protected Premises Unit) Remote Station (Protected Premises Unit) Local
System Service:	Automatic Fire Alarm Manual Fire Alarm Sprinkler Supervisory Waterflow Alarm Releasing Service for Pre-Action, Deluge
System Signal:	Radio Frequency Digital Alarm Communicator (DAC) March Time Non-Coded Reverse Polarity Other Technologies

## 3. Functionality

The panel utilizes a signaling line circuit for communication to various sensors and modules. The system polls the loop between every 4 to 5 seconds. The system is completely supervised and is designed to comply with UL 864. The control panel uses a proprietary protocol to digitally communication with various sensors and modules to determine the status of each. When the panel response from the sensor or module is within a pre-determined range or status, the control will process the commands accordingly.

The control panel user interface requires the use of a key to open the outer door. Advanced features will require an additional user code to be entered using a combination of numbers.

The panel is completely programmable through the use of a computer program. Remote programming is detailed later in this section.

The control panel includes three relay contacts for additional monitoring or building functions.

The first relay is a failsafe, dedicated Trouble Relay. This relay changes state during any trouble condition. This relay is not programmable and no additional mapping to this relay can take place.

The second relay is a dedicated Supervisory Relay. This relay changes state during any supervisory condition. This relay is not programmable and no additional mapping to this relay can take place.

The third relay is a dedicated Alarm Relay. This relay changes state during any alarm condition. This relay is not programmable and no additional mapping to this relay can take place.

The AFC-100 has two NACs and two I/O circuits. Each NAC is rated for 3 amps at 24 VDC. Each I/O circuit is configurable as a NAC rated for 1 amp at 24 VDC, or as a dry contact input. The NACs may be operated in Class A with the addition of a CA-6075 Class A Expander.

NACs may be programmed to provide steady (constant) voltage, a cadence pattern, releasing service or synchronized strobes. Full synchronization is maintained system-wide. The NACs may be programmed as silenceable or non-silenceable. Anytime a NAC has been silenced, the condition will be indicated by the silenced LED. If a NAC that is programmed as silenceable is silenced and another alarm event mapped to that NAC occurs, the NAC will resound and the silenced LED will extinguish.

The Low AC report delay period is programmable from 30 minutes up to 30 hours. For UL installations and applications the installer must set the time delay between 30 minutes and 90 minutes.

Supervisory Signal Operation – Zones programmed as supervisory zones can be programmed as latching or non-latching.

Trouble Signal Operation – Any fault or off normal that would impair the system is annunciated as a trouble condition. The trouble condition is specifically displayed on the LCD display so the trouble can be corrected. When a trouble occurs the buzzer sounds every ten seconds for one second, the trouble LED illuminates and the trouble relay changes state.

The panel transfers from AC to battery instantly upon AC failure or brownout. The trouble relay will indicate the low AC condition after the Low AC Report Delay has elapsed.

The control panel can utilize an optional digital alarm communicator transmitter, (UD-1000/UD-2000). The UD-1000/UD-2000 is a two line dialer with the capability to report in the Ademco Contact ID or the Security Industry Association's Digital Communications Standard (SIA-DCS).

When equipped with a UD-1000/UD-2000, the status changes of the panel are remotely communicated to a monitoring station. Programming options allow for selecting separate accounts for alarm/trouble/supervisory/test events. When a UD-1000/UD-2000 is not installed, the panel will operate as a local system.

The DACT will provide a daily test to a remote monitoring point daily. The daily test time is programmable. If two phone lines are utilized, the DACT will alternate between lines on each daily call. If multiple accounts are programmed, then multiple daily tests will be conducted alternating on each line.

The panel may be equipped with 31 PSN-1000 series intelligent power expanders. The PSN-1000/PSN-1000(E) is a 10 amp notification power supply and P-Link (RS-485) repeater. The power supply connects to the P-Link bus from the control panel and is operated and supervised from the panel.

The power supply has six (6) Class B or three (3) Class A power outputs. Each output is regulated and power limited with a 3 Amp maximum rating. In addition, the PSN-1000s have two (2) programmable dry contact inputs. The dry contact inputs are Class B, supervised inputs.

The power supply operates on either 120 or 220 VAC power and has a regulated 24 VDC output. In addition, the panel can charge up to 55 AH batteries and will house 18 AH batteries.

The power supplies are programmed and controlled through the main control panel P-Link bus. The panel displays any troubles or off normal conditions of the power supply and the events are stored in the panel history buffer.

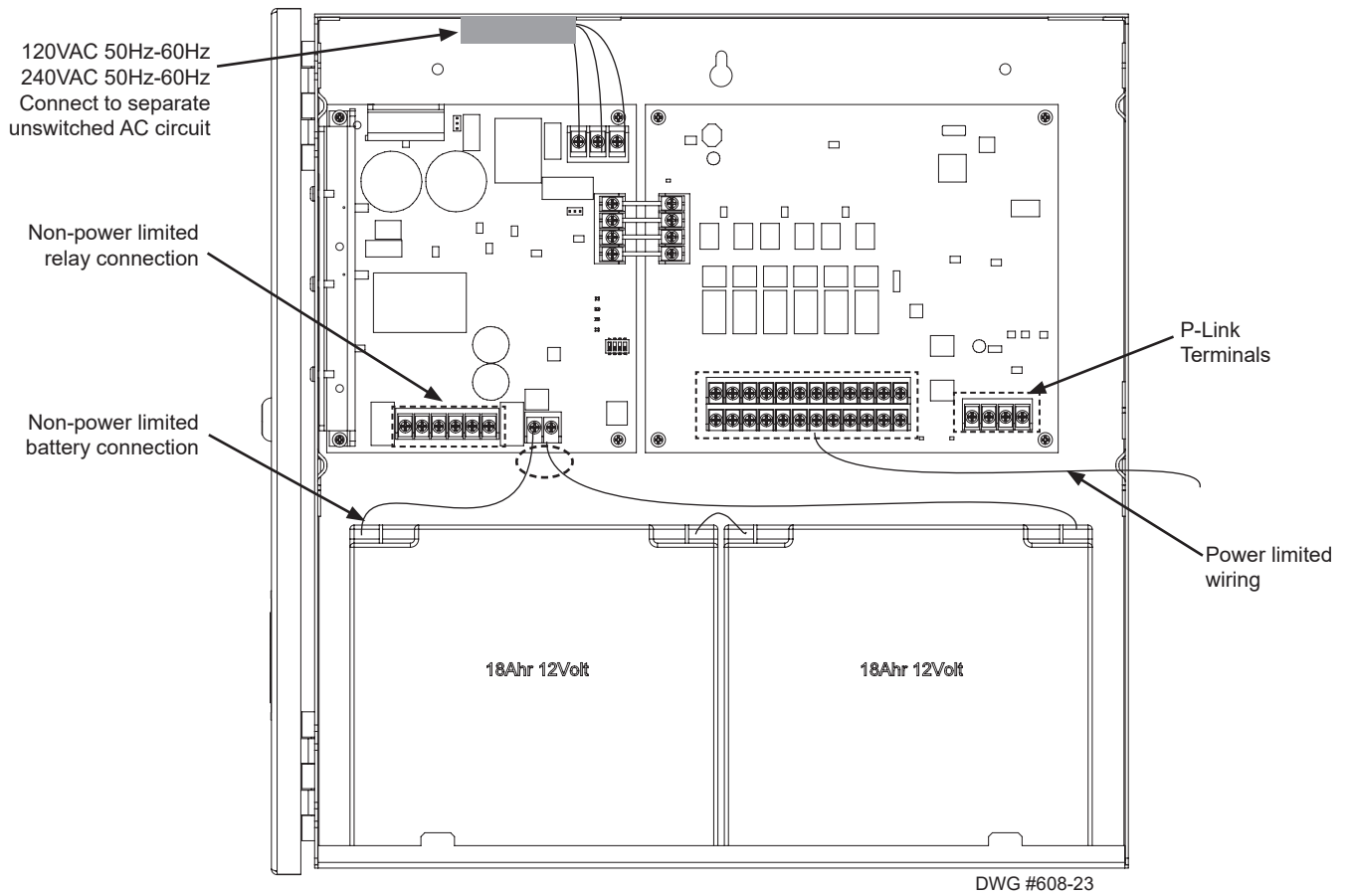

Figure 20. PSN-1000 Wiring Example

The panels may be equipped with one PAD100-SLCE (PAD Protocol) or a Nohmi Protocol SLCE-127 board if the built-in SLC is disabled. The PAD100-SLCE and SLCE-127 boards utilize a signaling line circuit for communication to various sensors and modules. The system polls the loop between every 4–5 seconds. Both boards support a maximum of 100 addressable devices configured in any combination of smoke sensors, heat detectors, input modules or output modules.

The PAD100-SLCE and the SLCE-127 outputs are supervised and regulated. Circuits are low voltage and power limited. All wiring must be separated by at least 0.25 inches and the wire insulation must be for the higher voltage. Refer to Figure 19 for suggested wire routing.

The PAD100-SLCE and the SLCE-127 are supplied with a mounting bracket which allows it to be mounted into a compatible fire enclosure. Please refer to the figures shown below:

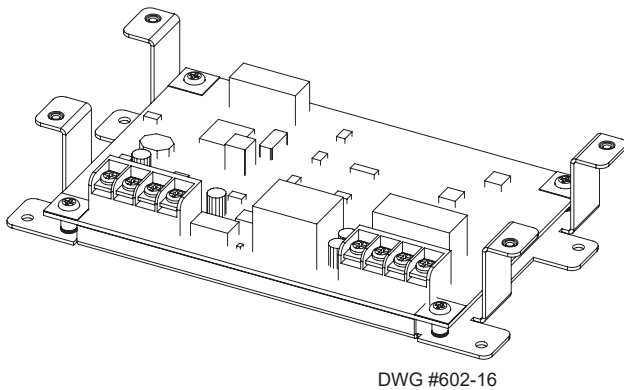

Figure 21. PAD100-SLCE / SLCE-127 Board & Showing Mounting Bracket

When the panels are equipped with a LED-16/LED-16(F) module, alarm/supervisory/trouble conditions display for up to 16 zones. Blank zone labels are provided for use with the LED-16s. Zone names/identifiers can be typed or written on the supplied card-stock, and then inserted into the LED-16/LED-16F as shown below.

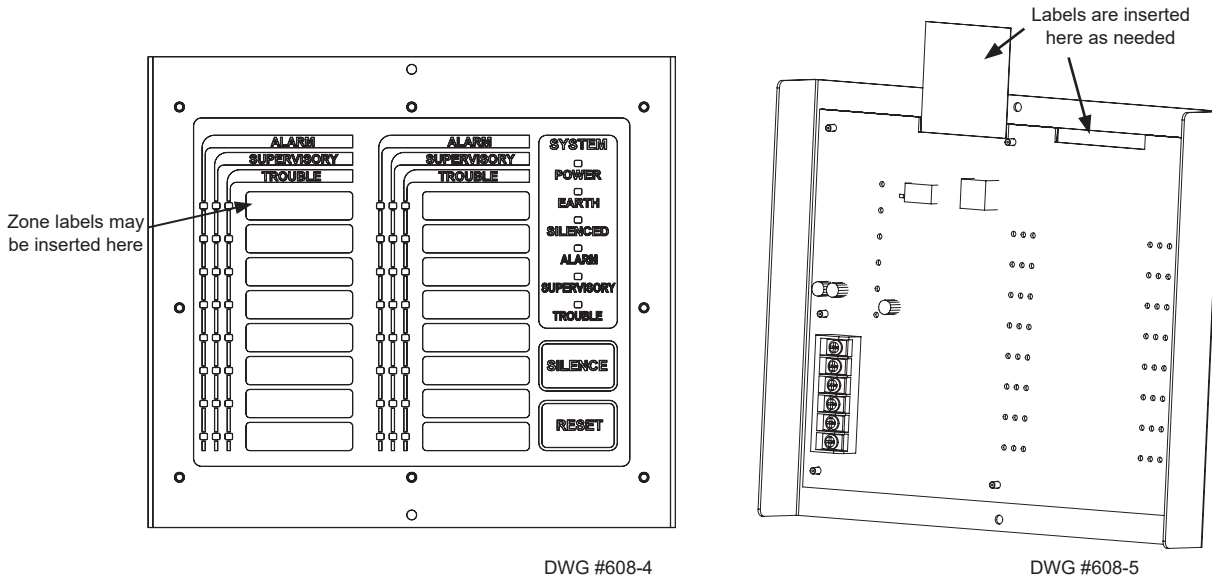

Figure 22. LED-16/LED-16(F) Module & Board

The LED-16s are controlled over the 4-wire P-Link connection. The higher current required for the LED outputs can be provided by the panel, or from an auxiliary power source as shown below. The auxiliary power can be any fire listed 24VDC source, and is fully supervised.

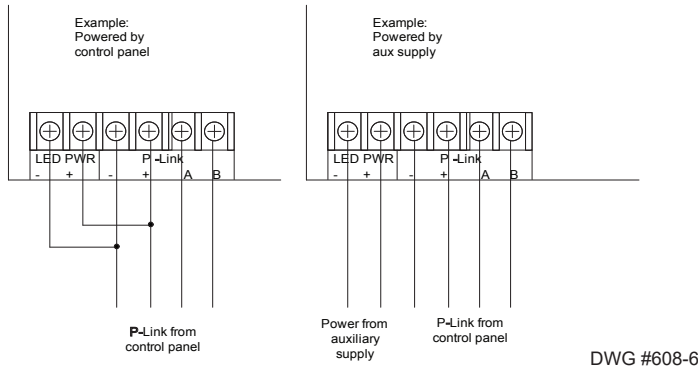

Figure 23. Examples of Wiring a LED-16/LED-16(F) Module to Control Panel or Auxiliary Power Supply

The panel may be equipped with a DRV-50 (LED Driver) module, which can be individually mapped to any zone. The DRV-50 is controlled over the 4-wire P-Link connection. The DRV-50 mounts in a mounting bracket as shown below. This can then be mounted into any of the compatible fire enclosures, or the AE-2, AE-8 or AE-14 accessory cabinets.

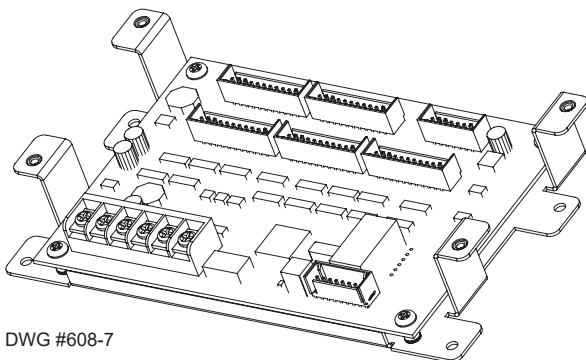

Figure 24. DRV-50 Board Showing Mounting Bracket

The 50 programmable LED outputs are located on connectors P1-P5, each containing 10 LED outputs and two 5VDC outputs. The system LEDs & PZT control outputs are located on connector P6. LEDs are wired as shown below, no external resistor is required. All outputs are power limited. All connections to P1-P6 are limited to same room installation.

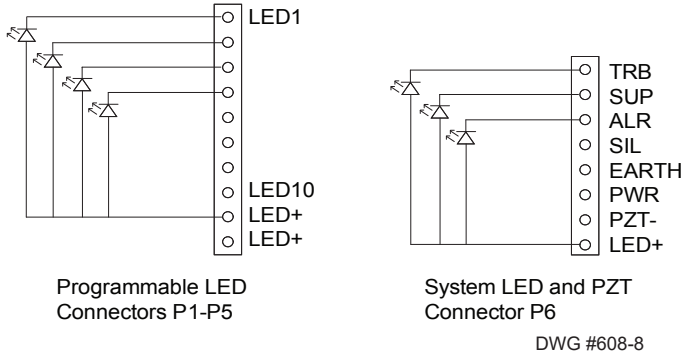
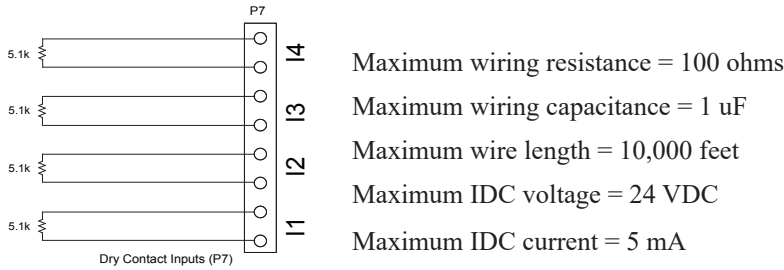

Figure 25. DRV-50 "P1-P5" and "P6" Connectors

The 4 programmable dry-contact inputs are located on connector P7. All input circuits are power limited and use UL listed 5.1k EOL resistor (Potter part #3005013). The inputs can be programmed for any of the contact input functions available for other input circuits available on the panel. Inputs I1-I4 are Class B dry contact inputs only. All contact inputs are fully supervised. Ground fault detection impedance is 0 ohms.



DWG #608-9

Figure 26. DRV-50 Dry Contact Input "P7" Connector

The higher current required for the DRV-50 outputs can be provided by the panel, or from an auxiliary power source as shown below. The auxiliary power can be any fire listed 24VDC source, and is fully supervised. Output power must be 16 VDC-33 VDC, and must be power limited.

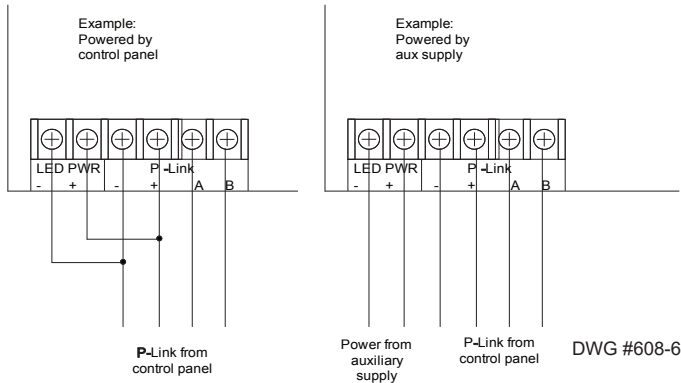

Figure 27. Examples of Wiring DRV-50 from Control Panel or Auxiliary Power Supply

The panel may be equipped with a RLY-5 (Relay Board) module, which is controlled over the 4-wire P-Link connection. The RLY-5 mounts in a mounting bracket as shown below. The RLY-5 can be mounted inside the panel cabinet, or the AE-2, AE-8 or AE-14 accessory cabinets.

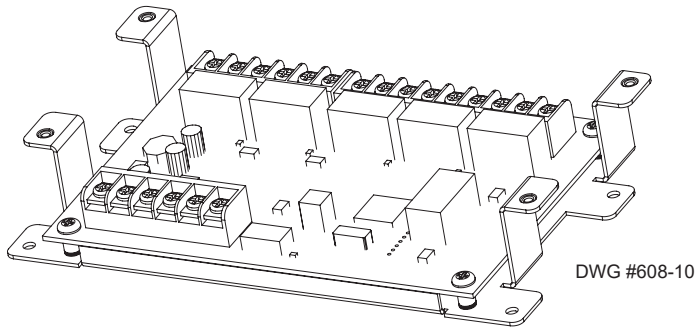

Figure 28. RLY-5 Board Showing Mounting Bracket

The RLY-5 higher current required for the relay outputs can be provided by the panel, or from an auxiliary power source as shown below. The auxiliary power can be any fire listed 24VDC source, and is fully supervised. Output power must be 16VDC-33VDC, and must be power limited.

- Relay contacts are rated for 120VAC/24VDC, 3 Amp (resistive).
- All connections to relay contacts shall be power limited.
- Not to be used for off-premise signaling.

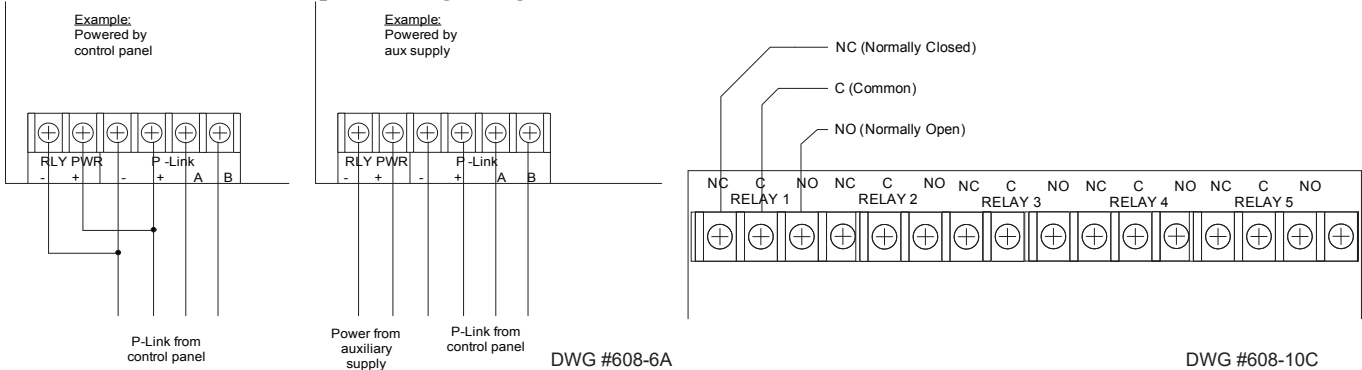

Figure 29. RLY-5 Wiring to Control Panel / Auxiliary Power Supply & RLY-5 Normally Open / Normally Closed Contacts

When the FCB-1000 (Fire Communications Bridge) is added to the panel, a remotely-located IP connection is provided into the panel. The FCB-1000 can be mounted inside the AE-2, AE-8 or AE-14 accessory enclosure. The optional rack-mount kit (FCB-1000RM) includes a standard 19 inch rack-mount enclosure, which can then be installed directly in an equipment rack.

**Note:** The Ethernet/IP connection is limited to same room installation. This connection shall be limited to 20 feet, and enclosed in conduit or equivalently protected against mechanical injury.

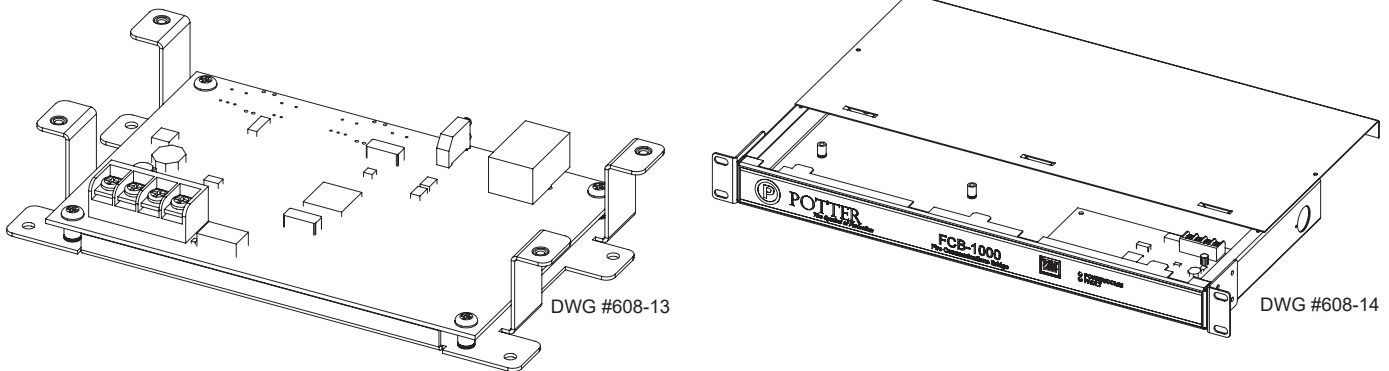

Figure 30. FCB-1000 Bridge & FCB-1000RM Showing Rack Mount



When the panel is equipped with the FIB-1000 (Fiber Interface Bridge) optional board, the standard 4 wire P-Link bus may be converted to/from the fiber optic cable.

The FIB-1000 can be mounted inside the AE-2, AE-8 or AE-14 accessory enclosure. The optional rack-mount kit (FIB-1000RM) includes a standard 19 inch rack-mount enclosure, which can then be installed directly in an equipment rack.

- Utilizes multimode 62.5/125 micron fiber optic cable (wave length = 820 nm)
- Tolerates up to 12 db of signal loss

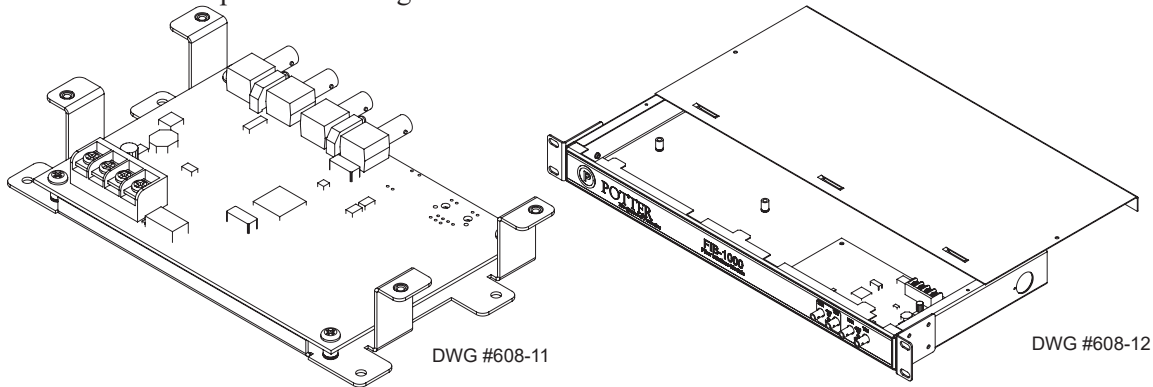

Figure 31. FIB-1000 Bridge & FIB-1000RM Showing Rack Mount

An optional SPG-1000 serial/parallel gateway (printer driver) board can be mounted inside the AE-2, AE-8 or AE-14 accessory enclosure. A rack-mount kit (SPG-1000RM) includes a standard 19 inch rack-mount enclosure, which can then be installed directly in an equipment rack.

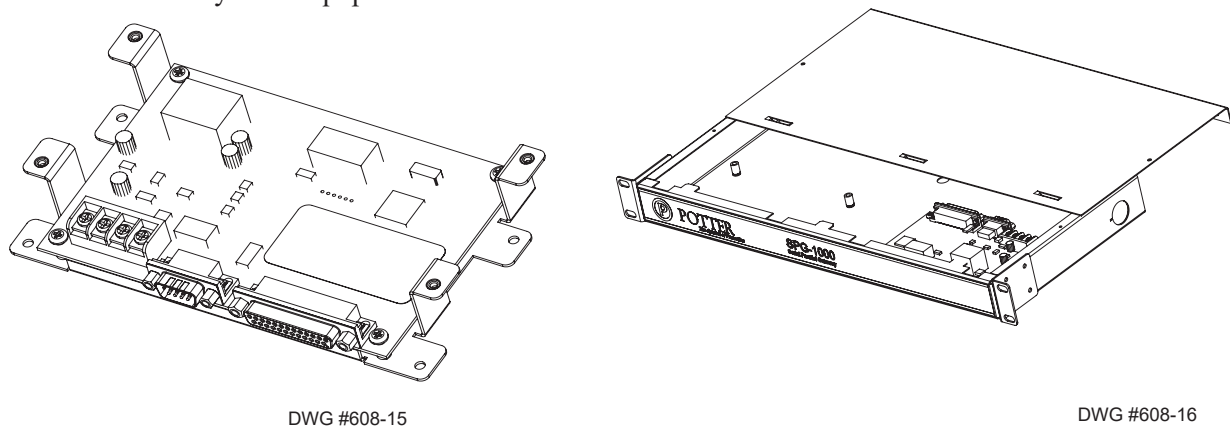

Figure 32. SPG-1000 Serial Parallel Gateway Board & Rack Mount

**Note:** Serial/Parallel printer connection is limited to same room installation. This connection shall be limited to 20 feet, and enclosed in conduit or equivalently protected against mechanical injury.

When the panel is equipped with the MC-1000 (Multi-Connect Module) optional board, up to 63 panels may be interconnected to report to the central station through a shared phone line or Internet connection.

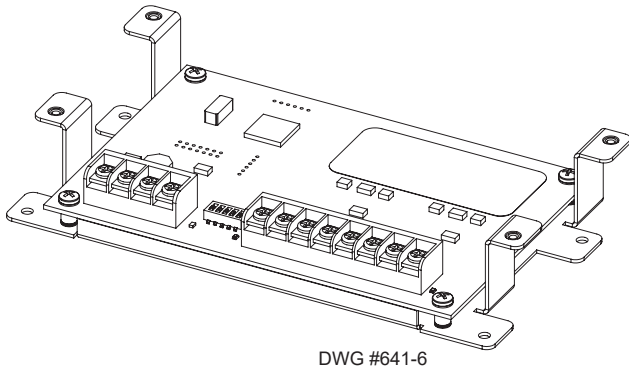

Figure 33. MC-1000 Multi-Connect Board & MC-1000 Showing Rack Mount

The panel supports up to thirty one (31) IDC-6 modules. The IDC-6 is controlled over the 4 wire P-Link connection. It can be mounted in PSN-1000 or either of the AE-2, AE-8 or AE-14 accessory cabinets..

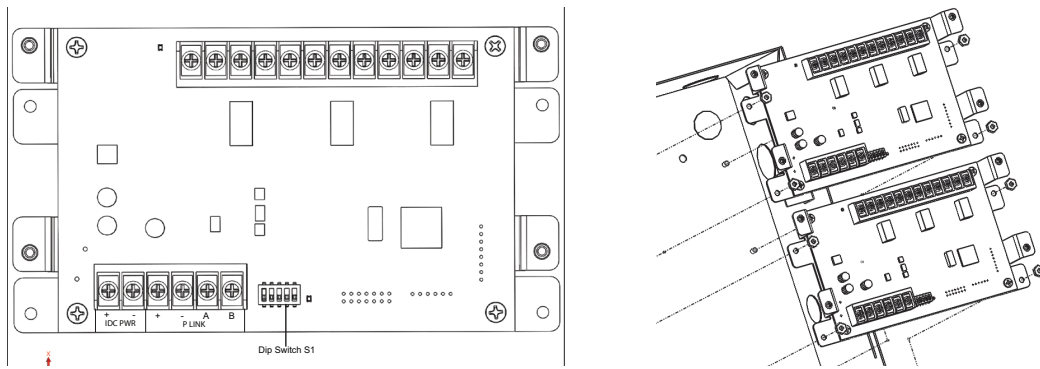

Figure 34. IDC-6 Initiating Device Circuit Expander and IDC-6 Installation

The IDC-6 higher current required for the inputs can be provided by the panel, or from an auxiliary power source as shown below. The auxiliary power can be any fire listed 24VDC source, and is fully supervised. IDC-6 operating voltage range is 15VDC-28VDC, and must be power limited.

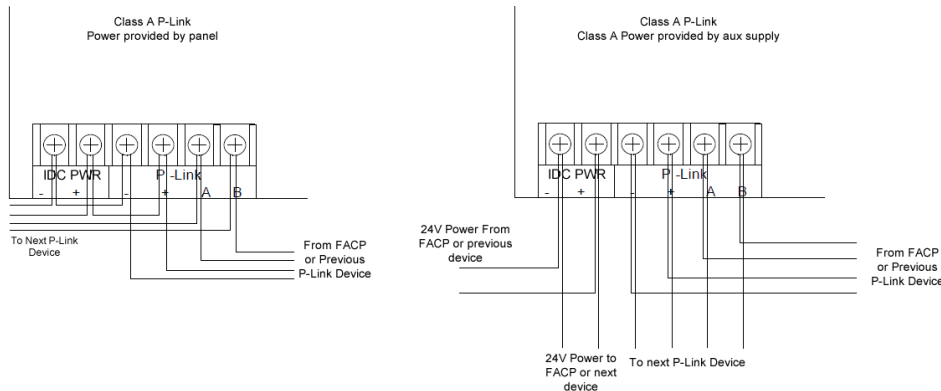

Figure 35. IDC-6 Class A Wiring

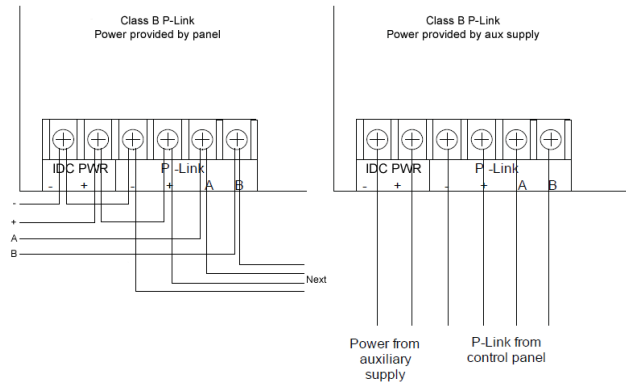

Figure 36. IDC-6 Class B Wiring

The NCE-1000 is used to network the fire alarm control panels via CAT5 Ethernet cable. It is fully supervised and is capable for Class B and Class A operation. The NCE-1000 can be used as a Class A extender which extends the length of the Ethernet connection from 300 feet to 600 feet. The NCE-1000 may be mounted in either the control panel cabinet, the PSN- 1000/E, the AE-2, AE-8 or AE-14. When wiring Class A or B, the connection between the FACP and the module shall be limited to 20 feet and enclosed in conduit or equivalently protected against mechanical injury. A maximum of 31 NCE-1000s can be installed per panel, with a maximum of 200 panels per network. Please refer to installation manual 5406326.

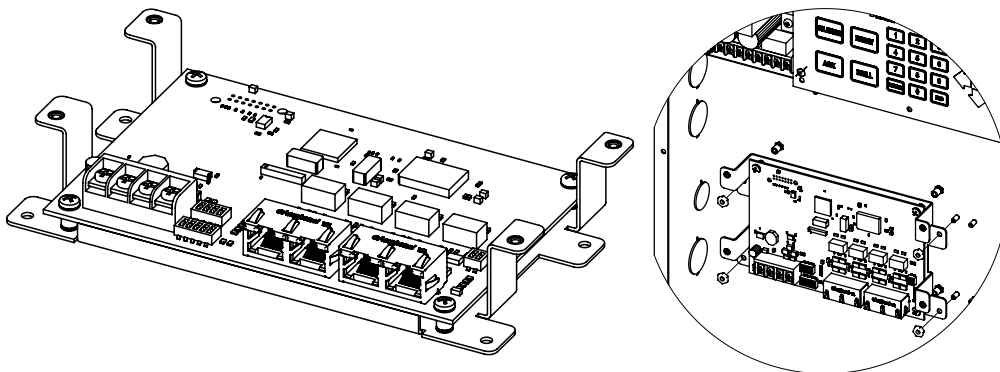

Figure 37. NCE-1000 Network Card

The NCF-1000 is used to network the fire alarm control panels using fiber optic cable. The NCF-1000 allows the user to install SFP (small form-factor pluggable) modules to utilize either single mode or multi-mode fiber. It is fully supervised and is capable of both Class B and Class A operation. The NCF-1000 may be mounted in either the control panel cabinet, the PSN-1000/E, the AE-2, AE-8 or AE-14. The connection between the FACP and the module shall be limited to 20 feet and enclosed in conduit or equivalently protected against mechanical injury. A maximum of 31 NCF-1000s can be installed per panel with a maximum of 200 panels per network. Please refer to installation manual 5406424.

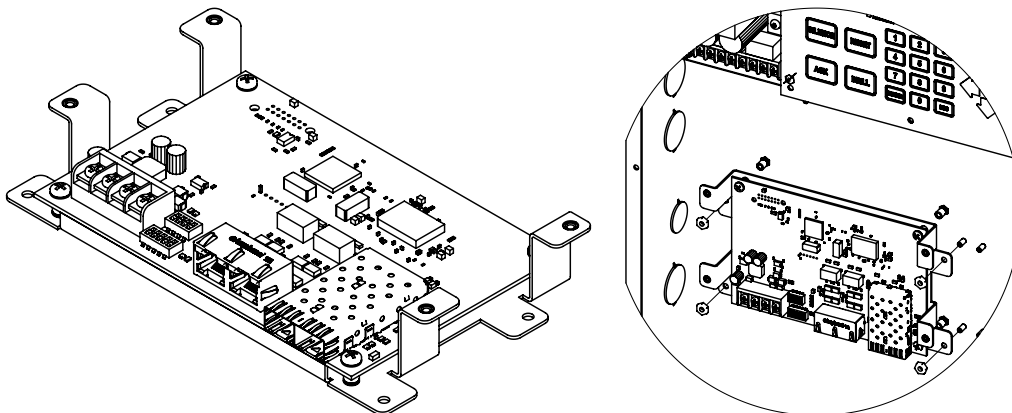

Figure 38. NCF-1000 Network Card Fiber

The control panel has an interface display for allowing users, technicians and installers the ability to recognize the status and input changes to the control panel. The display consists of three parts — the 32 character LCD display, the keypad and LEDs.

The keypad on the control panel is utilized for common user functions and system programming. The common user function buttons the following:

ACK – When pressed acknowledges the status change of the panel.

Signal Silence – When the button is pressed will silence outputs that are programmed as silenceable.

System Reset – When this button is pressed, the system will reset the panel to a normal condition. Once the reset is complete, any off normal status will be displayed.

Fire Drill – When programmed, the Fire Drill button will activate the programmed outputs to simulate an actual alarm without creating an alarm event.

The display has the following LEDs:

Power – A green LED that illuminates any time AC power is present

Alarm – A red LED that flashes any time an input programmed as an alarm device is active and has not been acknowledged. The LED will illuminate steady after all alarm conditions have been acknowledged.

Pre-Release – An amber LED that illuminates when a releasing zone is in a Pre-Discharge mode.

Release – A red LED that is on steady when a releasing output is active.

Earth Fault – An amber LED that flashes any time a ground fault is present on one of the control panel circuits and has not been acknowledged. The LED will illuminate steady after all earth faults have been acknowledged.

Supervisory – An amber LED that flashes any time an input programmed as supervisory is active and has not been acknowledged. The LED will illuminate steady after all supervisory conditions have been acknowledged.

Signal Silence – An amber LED that will illuminate any time the signal silence is active.

Trouble – An amber LED that flashes any time a trouble condition on the system is present and has not been acknowledged. The LED will illuminate steady after all trouble conditions have been acknowledged.

The control panel has the following functions:

Drift Compensation – The system employs drift compensation as a false alarm preventive measure. The drift compensation is controlled as part of the smoke head and not part of the control panel.

Calibrated Smoke Detector Sensitivity Testing – The control panel polls the smoke sensors for the current AD value approximately once every four seconds. Approximately every 4 minutes, the control panel polls the smoke sensors for the dirty value and compares the dirty value of the sensor to the alarm threshold. If the dirty value is 50% of the alarm threshold, a sensor trouble will be annunciated. A technician may also request the status of any sensor in the system through the front panel menu. In addition, a report can be printed that provides the level of sensitivity and the current level.

Remote Programming – The control panel is capable of being programmed remotely via the optional UD-1000/UD-2000 communicator. The remote modem calls the panel from a remote location and if programmed to answer phone calls it will pick up the call. Before the panel will accept any changes to the configuration data, an on-site user must enable the panel for remote access via the front panel keypad.

Positive Alarm Sequence – The control panel is programmable for Positive Alarm Sequence. When a zone is programmed as positive alarm sequence and an automatic sensor is activated, the user has up to 15 seconds to acknowledge the alarm. Failure to acknowledge the alarm will activate the evacuation appliances. If the alarm is acknowledged, the user has up to 180 seconds to reset the system. Failure to reset the system after the

acknowledgment timer will result in the evacuation signal being activated.

Alarm Verification – The control panel is programmable to enable alarm verification in compliance with UL 864 and NFPA 72. Zones with smoke sensors programmed as alarm verification when activated will delay the notification circuits from activating for up to 60 seconds. If the smoke sensor is still in the alarm condition after the programmed delay, the evacuation signals will activate.

**Note:** Alarm activation requiring activation of two or more automatic detection devices shall not utilize alarm verification or any other time delay.

The control panel maintains the date and time independently of the main or secondary power. The date and time can be changed through the front keypad menu. In addition, daylight savings time may be programmed into the system, the dates of the time change are programmable if this feature is selected.

When an appropriate pass code is entered via the key pad into the control panel, the user may disable a device within the system. Any addressable point, NAC or suppression circuit may be disabled. When a device or circuit is disabled, the panel will indicate the off-normal condition. When the device or circuit is enabled, the trouble will clear and the panel will operate in a normal fashion. More than one device or circuit may be disabled at any one time. The circuits may individually be enabled and not affect the others.

The control panel controls the alarm threshold of the smoke detectors programmed as part of the system. The alarm threshold is limited to the listed value of the smoke detector. The selectable range of sensitivity is 1.5 percent per foot obscuration to 3.5 percent per foot obscuration. The alarm threshold may be adjusted in the computer software.

The control panel may be programmed for Day and Night mode smoke detector alarm threshold. The smoke detectors must be programmed for the day and night mode in addition to the Day/Night mode being enabled. In addition, the programmer must select the days and times for the days and nights. Up to fifty holidays may be programmed for the night mode (more sensitive) setting. The alarm threshold is only programmable for the listed range of the detector.

The control panel utilizes a concept of software zones for mapping inputs to outputs. Inputs and outputs are mapped to a single or multiple zones and when an input activates, all of the outputs within the same zone are activated. The panel also supports Cross Zoning, Counting Zones or a combination of a Cross/Count Zone. Cross zoning requires two inputs from separate zones in order to activate an output. A counting zone requires two inputs within the same zone to activate an output. The combination of a Cross/Counting Zone is two inputs in different zone or two inputs within the same zone to activate an output.

#### 4. Programming Options

The control panel is configured using a PC based programming tool. The panel stores the site specific configuration data in non-volatile memory.

##### NOTICE TO USERS, INSTALLERS, AUTHORITIES HAVING JURISDICTION, AND OTHER INVOLVED PARTIES

This product incorporates field-programmable software. In order for the product to comply with the requirements in the Standard for Control Units and Accessories for Fire Alarm Systems, UL 864, certain programming features or options must be limited to specific values or not used at all as indicated below.

Topic	Feature or Option	Permitted in UL (Y/N)	Possible Settings	Setting(s) Permitted in UL864?	Comment
Misc	Idle LCD Message	Y	Yes/No	All Settings Allowed	
Misc	Display Events	Y	Initial Event Newest Event	Initial Event	Auto display of first event
Misc	SLC Blink	Y	Normal/Slow/Off	All Settings Allowed	
Misc	Alarm Verification Time	Y	0-60 Sec	All Settings Allowed	
Misc	Waterflow Delay	Y	0-255 Sec	All Settings Allowed	

Topic	Feature or Option	Permitted in UL (Y/N)	Possible Settings	Setting(s) Permitted in UL864?	Comment
Misc	AC Report Delay	Y	30 Minutes to 30 Hours	1-3 Hours	For UL864 use 1-3 Hr
Misc	DH Low AC Dropout Delay	Y	No delay, 15 Sec, 1 minute, 5 minute	All Settings Allowed	
Misc	Autotest Time	Y	Time of Day	All Settings Allowed	
Misc	Autotest Interval	Y	1-24 Hours	All Settings Allowed	
Misc	Strobes Active When Silenced	Y	Yes/No	All Settings Allowed	
Misc	50 Hz AC	Y	Yes/No	All Settings Allowed	
Misc	CO Tone on Annunciators	Y	Yes/No	All Settings Allowed	
Misc	Low Temp Events Are Supervised	Y	Yes/No	All Settings Allowed	
Misc	Disable 24 hours PZT Resound	Y	Yes/No	All Settings Allowed	
Misc	Display AM/PM	Y	AM/PM, 24 Hour	All Settings Allowed	
Misc	Synchronize to Network Time	Y	Yes/No	All Settings Allowed	
Misc	SNTP Server	Y	North-America.Pool.NTP.org	All Settings Allowed	
Misc	Time Zone	Y	24 Time Zone Selections	All Settings Allowed	
Misc	DST Enabled	Y	Yes/No	All Settings Allowed	
Misc	DST Start	Y	Month/Day	All Settings Allowed	
Misc	DST End	Y	Month/Day	All Settings Allowed	
Zone	Zone Style	Y	Alarm Supervisory PAS Auxiliary Releasing Fire Drill Waterflow Alert System Alarm System Supervisory System Trouble CO Alarm CO Supervisory	All Settings Allowed	
Zone	Alarm Count	Y	1-10	All Settings Allowed	
Zone	Silenceable	Y	Yes/No	All Settings Allowed	
Zone	Silence Inhibit	Y	Yes/No	All Settings Allowed	
Zone	Auto Silence	Y	Yes/No	All Settings Allowed	
Zone	Auto Unsilence	Y	Yes/No	All Settings Allowed	
Zone	Restore Delay	Y	0-300 Sec	Full range allowed	
Zone	Latching	Y	Yes/No	All Settings Allowed	
Zone	Local	Y	Yes/No	All Settings Allowed	

Topic	Feature or Option	Permitted in UL (Y/N)	Possible Settings	Setting(s) Permitted in UL864?	Comment
Zone	Output Pattern	Y	Constant ANSI Temp 3 March Code Double Time ANSI Temp 4	All Settings Allowed	
Zone	Day Sensitivity	Y	1.1%-3.5%	Full range allowed	Within listed range of sensor
Zone	Night Sensitivity	Y	1.1%-3.5%	Full range allowed	Within listed range of sensor
Zone	Heat Setting	Y	135F-185F	Full range allowed	Within listed range of sensor
Zone	Low Temp Heat Sens	Y	0F-135F	Full range allowed	
Zone	Enable PAD100 ROR	Y	Yes/No	All Settings Allowed	
Zone	Combo ROR/ Fixed Setting	Y	135F-174F	All Settings Allowed	Within listed range of sensor
SLC Point	Type PAD Protocol	Y	Photo Detector (PD) Fixed Heat Detector (HD) CO Detector (CO) Combination Photo/Heat Detector (PHD) Duct Detector (DUCT) Duct Detector w/Relay (DUCTR) Duct Detector Remote Test Switch (DRTS) Duct Remote LED Indicator (MS-RA) Duct LED w/Test Switch (MS-KA/P/R) Mini Input Module (MIM) Speaker Module (SM) Pull Station Module Single Action (PSSA) Pull Station Module Dual Action (PSDA) Relay Module (RM) Notification Appliance Circuit (NAC) Twin Relay & Twin Input (TRTI) Double Input Module (DIM) One Relay & One Input (OROI) Zone Module (ZM) Remote LED (LED) Remote LED w/Key (LEDK) Single Input Module (SIM)	All Settings Allowed	Specifies use/type of SLC device for PAD Protocol

Topic	Feature or Option	Permitted in UL (Y/N)	Possible Settings	Setting(s) Permitted in UL864?	Comment
SLC Point	Function PAD Protocol	Y	Sensor Only Sensor with Sound Base (AB) Sensor with Relay Base (RB) Sensor with Low Frequency Sounder Base (LFSB) Sensor with Speaker Base (SPKB) Sensor with Duct Relay Addr Relay General Purpose Addr Relay Zone Trouble Addr Relay HVAC Shutdown Addr Relay Reset Followers Addr NAC General Purpose Addr NAC Release Solenoid Addr Zone Module General Purpose Output Zone Trouble Output	All Settings Allowed	Specifies use/type of SLC device for PAD Protocol
SLC Point	Function Nohmi Protocol	Y	Photo Detector (PSA) Photo Duct Detector (DSA) Photo/Heat Detector (PSHA) Fixed Heat Detector (FHA) Combination Fixed / ROR Heat Detector (RHA) Conv. Zone Module (CIZM) Mini Contact Mod (MCM) Single Contact Mod (SCM) Dual Contact Mod (DCM) Mon. Output Mod (MOM) Twin Relay Mod (TRM) Sounder Base (ASB) Relay Base (ARB)	All Settings Allowed	Specifies use/type of SLC device for Nohmi Protocol
SLC Point	Dry Contact Input Functions PAD and Nohmi Protocol	Y	Pull Station Water Flow Supervisory Tamper Fire Drill Trouble Monitor Aux Abort Release Follower Reset Silence Fire Alarm Disable Inputs Disable Outputs Disable Inputs and Outputs Lamp Test CO Alarm CO Supervisory HVAC Reset Medical Alert Tornado Alert Process Alert Security Alert	All Settings Allowed	Applies to all dry-contact input devices & circuits  Disable Inputs, Disable Outputs, and Disable Inputs / Outputs <u>cannot</u> be assigned to a Releasing Zone to comply with UL 10th Edition.



Topic	Feature or Option	Permitted in UL (Y/N)	Possible Settings	Setting(s) Permitted in UL864?	Comment
SLC Point	Alarm Verif	Y	Yes/No	All Settings Allowed	
SLC Point	Supervisory	Y	Yes/No	All Settings Allowed	
NACs	Function	Y	General Purpose AMSECO Sync Gentex Sync Gentex Sync with T4 System Sensor Sync Wheelock Sync Constant Output Resettable Output Door Holder Output ANSII Output City Tie Output Release Solenoid Output Sounder Base Power	All Settings Allowed	Specifies use of NAC circuit(s)
Day/Night	Smoke Sensitivity	Y	Full listed range of smoke detector	All Settings Allowed	Up to 50 holidays where day mode is not active.
DACT	Daily Test Call	Y	Any time of day	All Settings Allowed	Alternates between line 1 and 2 if line 2 is enabled.
E-Mail	Email Status Reports	N	Alarms, Troubles, Supervisory, Test, History & Status Reports		
IP-Reporting	IP Based Central Station Reporting	Y	Alarm, Supervisory, Trouble & Test Reports	All Settings Allowed	

### Network Programming

Programming of a networks system uses all the above options. In addition, reference points are used to associate points between panels. Panels are also assigned to buildings allowing interactions between buildings via these reference points. Please refer to 8830161 Network Programming Guide and [www.pottersignal.com](http://www.pottersignal.com) for more information.

## 5. Testing/Maintenance

The control panel has one fuse on the board for the AC power over current protection.

The AC fuse is rated at 8A 250VAC Time-Lag and screened onto the main board as F1.

The batteries are to be replaced at least once every four years. The batteries are required to be UL recognized batteries with a date of manufacture permanently marked on the battery. The battery is to be tested at least annually and if the battery is showing signs of failure, it is to be replaced.

The battery is to remain in the cabinet with nothing on or around the batteries. Only properly sized sealed lead acid batteries are to be used with the control panel. Use of another battery or not providing the proper clearance may result in a fire or an explosions.

The control panel is required to be installed in accordance with local and state building codes and NFPA 72 (National Fire Alarm Code).

The control panel and related system is required to be inspected and tested in accordance with NFPA 72.

## 6. Compatibilities

### NAC Appliances

Please refer to Potter document 5403592 NAC Compatibility Document.

### Two Wire Smoke Detectors

None listed with the control panel, all devices listed the PAD100-ZM or CIZM, please refer to the PAD100-ZM or CIZM Installation Sheet.

**Note:** PAD100-ZM and CIZM modules require a 24 VDC power source. When using the CIZM, the power source must be 19.0 VDC – 26.4 VDC. When using the PAD100-ZM, the power source must be 19.6 VDC – 28 VDC. Power source must be power limited, and UL1481 listed.

**Releasing Compatibility Refer to Document #5403625.**

### Network Compatibility

The IPA series, AFC/ARC series and the PFC-4064 can be interconnected via the NCE and NCF network cards.

### SLC Devices

<b>Nohmi Protocol</b>	<b>PAD Protocol</b>
PSA – Photoelectric Smoke Detector	PAD100/PAD200-PD – Photo Detector
PSHA – Photoelectric Smoke Detector	PAD100-HD – Fixed Heat Detector
FHA – Fixed Temperature Heat Detector	PAD100-CD – CO Detector
RHA – Rate of Rise/fixed Temperature Heat Detector	PAD100/PAD200-PHD – Combination Photo/Heat Detector
DSA – Photo Duct Detector	PAD100/PAD200-DUCT – Duct Detector
APS-SA/DA – Addressable Pull Station (Single Action / Dual Action)	PAD100/PAD200-DUCTR – Duct Detector w/Relay
AIB – Addressable Isolator Base	PAD100/PAD200-DD – Duct Detector Sensor
ASB – Addressable Sounder Base	PAD100-DRTS – Duct Detector Remote Test Switch
ARB – Addressable Relay Base	MS-RA – DUCT Remote LED Indicator
MCM – Miniature Contact Module	MS-KA/P/R – DUCT LED w/Test Switch
SCM-4 – Single Contact Module	PAD100-MIM – Mini Input Module
DCM-4 – Dual Contact Module	PAD100-SM – Speaker Module
TRM-4 – Twin Relay Module	PAD100-PSSA – Pull Station Module Single Action
MOM-4 – Monitored Output Module	PAD100-PSDA – Pull Station Module Dual Action
CIZM-4 – Conventional Input Zone Module	PAD100-SB – Addressable Sounder Base
SCI – Short Circuit Isolator	PAD100-RB – Addressable Relay Base
	PAD100-IB – Addressable Isolator Base
	PAD100-IM – Isolator Module
	PAD100-RM – Relay Module
	PAD100-NAC – Notification Appliance Circuit
	PAD100-TRTI – Twin Relay-Twin Input
	PAD100-DIM – Double Input Module
	PAD100-OROI – One Relay-One Input
	PAD100-ZM – Zone Module
	PAD100-LED – Remote LED
	PAD100-LEDK – Remote LED w/Key
	PAD100-SIM – Single Input Module
	PAD100-LFSB - Low Frequency Sounder Base
	PAD100-SPKB - Speaker Base

## DACT/DACR Compatibility

### UD-1000/UD-2000 DACT

The DACT transmits in Ademco Contact ID and Security Industries Association's Digital Communication Standards (SIA-DCS). Each account may be configured for Contact ID or SIA-DCS independent of the other accounts setting. Therefore some account(s) could be Contact ID and others could be SIA-DCS or vice versa. Similarly, accounts could be the same reporting type.

### Compatible Receivers

Silent Knight Model 9500/9800 (Ademco MX8000)

Sur-Gard System III

SG-DRL3 (POTS Line Card)

### IP Reporting Compatibility

Sur-Gard System III

SG-DRL3-IPCA (Network Line Card)

#### Notes:

Where the fire alarm transmitter is sharing on-premises communications equipment, the shared equipment shall be Listed.

Secondary power shall be provided for all equipment necessary for the transmission and reception of alarm, supervisory and trouble signals at the protected premises.

Secondary power shall be provided for all equipment necessary for the transmission and reception of alarm, supervisory and trouble signals at the supervising station.

The connection between the FACP and on-premises communications equipment shall be limited to 20 feet and enclosed in conduit or equivalently protected against mechanical injury.

### RS-485 Devices

PAD100-SLCE	Provides a PAD protocol SLC loop with a maximum of 100 addressable points.
SLCE-127	Provides a Nohmi protocol SLC loop with a maximum of 100 addressable points.
RA-6500R / RA-6500F	4x40 character LCD Remote Annunciator
RA-6075R	2x16 character LCD Remote Annunciator
PSN-1000/E	10 Amp Power Expander
LED-16 / LED-16F	Device that displays alarm/supervisory/trouble conditions for up to 16 zones and five (5) non-programmable system LEDs that annunciate system's overall conditions (Power, Earth, Silenced, Alarm, Supervisory, & Troubles).
DRV-50	Device that provides 50 LED outputs can be individually mapped to any zone, four (4) programmable supervised dry contact inputs, and five (5) non-programmable system LEDs annunciate the overall system condition (Power, Earth, Silenced, Alarm, Supervisory, & Troubles).
RLY-5	Device that provides five (5) Form-C relay outputs which can be individually mapped to any zone.
FCB-1000	Device that provides remote IP connection.
FIB-1000	Device that converts the 4 wire P-Link bus to/from fiber optic cable.
MC-1000	Allows up to 63 AFC series panels to report to the central station through a shared phone line or Internet connection.
IDC-6	Device provides six (6) additional conventional Class B inputs or three (3) Class A inputs that can be individually mapped to any zone
NCE-1000	Device that is used to network fire alarm panels using CAT5 Ethernet cable.
NCF-1000	Device that is used to network fire alarm panels using fiber optic cable.

**Class A Expander**

CA-6075 Class A Expander

**Printers**

Keltron 90 Series Fire Alarm printer or other UL Listed fire alarm printer (Ancillary).

**7. System Configurations****AFC-100 (100 Point System)**

Model	Description	Local	Releasing Service	Auxiliary	Remote Station	Central Station	Proprietary
AFC-100	Main Board/Panel Assembly	Y	Y	Y	Y	Y	Y
CA-6075	Class A Expander	O	O	O	O	O	O
UD-1000/UD-2000	DACT	N	N	N	Y	Y	Y
PAD100-SLCE	PAD Protocol SLC Loop Expander	O	O	O	O	O	O
SLCE-127	Nohmi Protocol SLC Loop Expander	O	O	O	O	O	O
RA-6075R	LCD type remote Annunciator	O	O	O	O	O	O
RA-6500R, RA-6500F	LCD type remote Annunciator	O	O	O	O	O	O
PSN-1000	Fire Power Expander	O	O	O	O	O	O
LED-16/LED-16F	LED Annunciator	O	O	O	O	O	O
DRV-50	LED Driver	O	O	O	O	O	O
RLY-5	Relay Expander	O	O	O	O	O	O
FCB-1000	Fire Communications Bridge	O	O	O	O	O	O
FIB-1000	Fiber Interface Bridge	O	O	O	O	O	O
SPG-1000	Serial/Parallel Gateway	O	O	O	O	O	O
MC-1000	Multi-Connect Module	O	O	O	O	O	O
IDC-6	Initiating Device Circuit	O	O	O	O	O	O
NCE-1000	Network Card Ethernet	O	O	O	O	O	O
NCF-1000	Network Card Fiber	O	O	O	O	O	O
3005013	End of line resistor	Y	Y	Y	Y	Y	Y
3005012	End of line resistor and diode	N	Y	Y	N	N	N

Y = Yes, required for applicable section.

N = No, not required for applicable section.

O = Optional, may or may not be used, has no affect on the applicable section.

## 8. System Power/Size

Panel	# NACs	Rating per NAC	SLC Power	Notes	Class
AFC-100	2 up to 4 if all I/O circuits configured as NACs	3 Amp	Maximum Load of 90.61 mA	One SLC Loop	SLC – Class A or B NAC – Class A or B P-Link – Class A or B I/O – Class B only  All are low voltage and power limited

### System Size

Accessories/subassemblies	Maximum System Size
AFC-100	100 maximum points any combination of detectors or modules
	2 notification circuits on the main board 2 I/O circuits
UD-1000/UD-2000	1 DACT

---

<b>Normal Standby</b>	The green AC POWER LED will be illuminated and the user defined message on the LCD will be displayed. If the AC power is removed for more than 5 seconds, the green AC power LED will extinguish.
<b>Acknowledging</b>	Off normal events are acknowledged by pressing the ACK key while reviewing events. After all events have been acknowledged, the buzzer will deactivate and the associated LED will stop flashing and remain on continuously. During Positive Alarm Sequence operation the “ACK” key must be pressed within 15 seconds of the alarm initiation to activate the investigation timer.
<b>Alarm Condition</b>	The red ALARM LED will be illuminated anytime an alarm is occurring in the system. The LCD will display the number of inputs in alarm, and the buzzer will be activated. The buzzer will remain active until all alarms have been acknowledged, or until the Silence key is pressed.
<b>Silencing Alarm</b>	When the system is in Alarm, the notification circuits (strobes and horns) can be shut off by pushing the SILENCE button.
<b>Resetting Alarm</b>	After the condition that caused the alarm has been identified and corrected, the system may be reset to the Normal Standby by pressing the RESET button.
<b>Supervisory Condition</b>	When a supervisory condition is detected, the amber SUPERVISORY LED will illuminate and the buzzer will sound. The LCD display will indicate the number of supervisory events that are active. The local buzzer will sound until all supervisory events have been acknowledged.
<b>Restoring Supervisory Condition</b>	If the Supervisory condition is non-latching, once the device is restored to the normal condition, the supervisory event will clear. If the supervisory condition is latching, the device that was activated must be restored and the RESET pressed.
<b>Trouble Condition</b>	When a fault condition occurs, the amber TROUBLE LED will illuminate and the local buzzer will sound until the fault is removed or the ACK button is pressed acknowledging the trouble condition. If the buzzer is acknowledged and the fault is not removed within 24 hours, the buzzer will resound.
<b>Silencing Trouble(s)</b>	When a trouble is occurring, the local buzzer will sound until either all troubles have been acknowledged or the SILENCE button is pressed.
<b>Ground Fault</b>	When a conductor contacts and earth ground, the amber EARTH FAULT LED will illuminate and the LCD display will provide further information of where the fault is located.
<b>Pre-Release (Releasing Panels Only)</b>	The amber Pre-Release LED will illuminate when the system is in a count down timer for an agent release. Additionally, pre-release events and countdown timers are displayed on the LCD.
<b>Release (Releasing Panels Only)</b>	The red Release LED will illuminate when a release condition is active. Additionally, release events will be displayed on the LCD.
<b>Agent Release Abort (Releasing Panels Only)</b>	If the system is being used as an agent releasing panel and a pre-discharge timer is programmed, the release may be aborted by pressing the abort switch. For ULI installations, pushing the Abort will allow the timer to countdown until 10 seconds and then halt. Releasing and reactivating the Abort will set the timer to 10 seconds.
<b>Testing and Maintenance</b>	Test this system monthly or more frequently as required by the AHJ. Before conducting any testing contact the building personnel and the monitoring facility as applicable. When testing a system configured for releasing, activate the releasing disconnect switch to prevent accidental discharge of a suppression system. Test the circuits as outlined in the Installation Manual. Test in accordance with NFPA 72 Inspection, Testing and Maintenance Chapter(s) and any local requirements. The batteries should be marked with the date of installation and replaced every four years or sooner if battery trouble occurs. Batteries should be checked with a tester acceptable to the AHJ such as a Stone Technologies model STC612A or equivalent. In case of a fuse replacement, refer to the Installation Manual for the proper rating. Contact the agency below for service or operational questions.

---

For service, contact:

Name: \_\_\_\_\_

Company: \_\_\_\_\_

Address: \_\_\_\_\_

Telephone: \_\_\_\_\_

## Appendix A: Battery Calculation Worksheets

Description	Quantity	Standby (mA)	Total Standby (mA)	Alarm (mA)	Total Alarm (mA)
Main board (AFC-100)	1	130	<b>130</b>	220	
LCD Remote RA-6075R		20		25	
LCD Remote RA-6500R or RA-6500F		20		25	
CA-6075 Class A Expander		12		44	
UD-1000/UD-2000 DACT		16		23	
PSN-1000/E Power Expander		15		15	
LED-16 or LED-16F P-Link Current LED-Current (if applicable, see Note 5)		25 15		25 210	
DRV-50 LED-Current (#LEDs x 5 mA; if applicable, see Note 5)		25 10		25 215	
RLY-5 Relay Current (if applicable, see Note 5)		25 10		35 135	
FCB-1000 Fire Communications Bridge		25		25	
FIB-1000 Fiber Interface Bridge		30		30	
SPG-1000 Serial Parallel Gateway		40		40	
MC-1000 Multi-Connect Module		10		10	
IDC-6 Initiating Device Circuit		20		20	
IDC PWR (See Note 5)					
Class B Input Zones (Per Zone)		5		45	
Class A Input Zones (Per Zone)		5		45	
NCE-1000		50		50	
NCF-1000		95		95	
NAC 1					
NAC 2					
I/O 1					
I/O 2					
Built-in SLC Current Draw - Calculated by SLC worksheet					
		Total (mA)		Total (ma)	
Convert to Amps			x 0.001	Convert to Amps	x 0.001
(*Refer to maximum allowable standby current) Total A:				Total A:	
Multiply by standby hours			x ____	60 minutes per hour Alarm time (minutes) <i>Example:</i> 5 minute alarm: enter 12 10 minute alarm: enter 6	÷ ____
Total Standby AH				Total Alarm AH	
				+Total Standby AH	
				Total AH	
				Efficiency Factor	÷ 0.80
				<b>Required AH</b>	

<p><b>*Maximum Allowable Standby Current</b> (UL 24-Hour standby time)</p> <table> <tr> <td>7 AH</td> <td>.215 A</td> </tr> <tr> <td>18 AH</td> <td>.582 A</td> </tr> <tr> <td>33 AH</td> <td>1.082 A</td> </tr> <tr> <td>55 AH</td> <td>1.815 A</td> </tr> </table>	7 AH	.215 A	18 AH	.582 A	33 AH	1.082 A	55 AH	1.815 A	<p><b>Important Notes:</b></p> <ol style="list-style-type: none"> <li>1) FACP enclosure can house up to two (2) 18 AH batteries. Larger batteries require accessory enclosure, part #SSU00500.</li> <li>2) NFPA 72 requires 24 hours of standby power followed by 5 minutes alarm activation.</li> <li>3) Door holder circuits configured to disconnect upon AC loss need not be included in the battery standby calculation since they will not draw power during that time. Door holders will contribute to standby current draw when AC is present.</li> <li>4) Total current must not exceed power supply rating (5.0A).</li> <li>5) LED/Relay/IDC-6 current must be accounted for in the battery calculation for the supplying source.</li> </ol>
7 AH	.215 A								
18 AH	.582 A								
33 AH	1.082 A								
55 AH	1.815 A								



**Built-in SLC Current Draw Worksheet (PAD Protocol)**

Device Type	Qty	Standby (mA)	Total Standby (mA)	Alarm Standby (mA)	Total Alarm (mA)
Photo detector (PAD100/PAD200-PD)		.300		.300	
Fixed heat detector (PAD100-HD)		.300		.300	
CO detector (PAD100-CD)		.300		.300	
Combination photo/heat detector (PAD100/PAD200-PHD)		.300		.300	
Duct detector (PAD100/PAD200-DUCT)		.300		.300	
Duct detector w/relay (PAD100/PAD200-DUCTR) *Notes 4 & 5		.500		.500	
Duct detector remote test switch (PAD100-DRTS)		10.0		15.0	
Mini input module (PAD100-MIM)		.200		.200	
Speaker Module (PAD100-SM)		.240		.240	
Pull station module single action (PAD100-PSSA)		.200		.200	
Pull station module dual action (PAD100-PSDA)		.200		.200	
Relay module (PAD100-RM)		.240		.240	
Notification appliance circuit (PAD100-NAC) *Note 2		.200		.200	
Twin relay-twin input module (PAD100-TRTI)		.240		.240	
Double input module (PAD100-DIM)		.240		.240	
One relay-one input module (PAD100-OROI)		.240		.240	
Zone module (PAD100-ZM) *Note 1		.240		.240	
Remote LED (PAD100-LED)		.240		.240	
Remote LED with key (PAD100-LEDK)		.200		.200	
Single input module (PAD100-SIM)		.240		.240	
Addressable sounder board (PAD100-SB) *Note 3		.200		.200	
Addressable Low Frequency Sounder Base (PAD100-LFSB) *Note 6		.200		.200	
Addressable Relay board (PAD100-RB)		.200		.200	
Isolator base (PAD100-IB)		.150		.150	
Isolator module (PAD100-IM)		.150		.150	
SLC alarm LED Current	n/a	n/a		n/a	36.0
		<b>SLC Standby Current</b>		<b>SLC Alarm Current</b>	

\* Note 1: PAD100-ZM requires 24VDC power source. Standby current = 15.0 mA. Alarm Current = 60.0 mA.

\* Note 2: PAD100-NAC requires 24VDC power source. Standby current = 3.0 mA. Alarm Current = 8.0 mA.

\* Note 3: PAD100-SB requires 24VDC power source. Standby current = 4.0 mA. Alarm Current = 30.0 mA.

\* Note 4: PAD100-DUCTR requires 24VDC power source. Standby current = 30.0 mA. Alarm Current = 60.0 mA.

\* Note 5: When connecting the MS-RA/MS-KA/P/R power source, Standby current = 45.0 mA. Alarm Current = 90.0 mA.

\* Note 6: PAD100-LFSB requires 24VDC power source. Standby current = 4.1 mA. Alarm Current = 156.6 mA.

## SLC Current Draw Worksheet (PAD Protocol) (Complete for configuring the PAD100-SLCE)

Device Type	Qty	Standby (mA)	Total Standby (mA)	Alarm Standby (mA)	Total Alarm (mA)
PAD100-SLCE SLC board (PAD Protocol)		60	60	60	60
Photo detector (PAD100/PAD200-PD)		.300		.300	
Fixed heat detector (PAD100-HD)		.300		.300	
CO detector (PAD100-CD)		.300		.300	
Combination photo/heat detector (PAD100/PAD200-PHD)		.300		.300	
Duct detector (PAD100/PAD200-DUCT)		.300		.300	
Duct detector w/relay (PAD100/PAD200-DUCTR) *Notes 4 & 5		.500		.500	
Duct detector remote test switch (PAD100-DRTS)		10.0		15.0	
Mini input module (PAD100-MIM)		.200		.200	
Speaker Module (PAD100-SM)		.240		.240	
Pull station module single action (PAD100-PSSA)		.200		.200	
Pull station module dual action (PAD100-PSDA)		.200		.200	
Relay module (PAD100-RM)		.240		.240	
Notification appliance circuit (PAD100-NAC) *Note 2		.200		.200	
Twin relay-twin input module (PAD100-TRTI)		.240		.240	
Double input module (PAD100-DIM)		.240		.240	
One relay-one input module (PAD100-OROI)		.240		.240	
Zone module (PAD100-ZM) *Note 1		.240		.240	
Remote LED (PAD100-LED)		.240		.240	
Remote LED with key (PAD100-LEDK)		.200		.200	
Single input module (PAD100-SIM)		.240		.240	
Addressable sounder board (PAD100-SB) *Note 3		.200		.200	
Addressable Low Frequency Sounder Base (PAD100-LFSB) *Note 6		.200		.200	
Addressable Relay board (PAD100-RB)		.200		.200	
Isolator base (PAD100-IB)		.150		.150	
Isolator module (PAD100-IM)		.150		.150	
SLC alarm LED Current	n/a	n/a		n/a	36.0
		<b>SLC Standby Current</b>		<b>SLC Alarm Current</b>	

\* Note 1: PAD100-ZM requires 24VDC power source. Standby current = 15.0 mA. Alarm Current = 60.0 mA.

\* Note 2: PAD100-NAC requires 24VDC power source. Standby current = 3.0 mA. Alarm Current = 8.0 mA.

\* Note 3: PAD100-SB requires 24VDC power source. Standby current = 4.0 mA. Alarm Current = 30.0 mA.

\* Note 4: PAD100-DUCTR requires 24VDC power source. Standby current = 30.0 mA. Alarm Current = 60.0 mA.

\* Note 5: When connecting the MS-RA/MS-KA/P/R power source, Standby current = 45.0 mA. Alarm Current = 90.0 mA.

\* Note 6: PAD100-LFSB requires 24VDC power source. Standby current = 4.1 mA. Alarm Current = 156.6 mA.

## SLC Current Draw Worksheet (Nohmi Protocol) (Complete for configuring a SLCE-127)

Device Type	Qty	Standby (mA)	Total Standby (mA)	Alarm (mA)	Total Alarm (mA)
SLCE-127 SLC Board (Nohmi Protocol)		60	60	60	60
Analog photo smoke detector (PSA)		0.325		0.325	
Analog photo smoke / fixed heat detector (PSHA)		0.325		0.325	
Analog fixed temperature heat detector (FHA)		0.325		0.325	
Analog rate of rise/fixed temperature heat detector (RHA)		0.325		0.325	
Analog photo DUCT smoke detector (DSA)		0.325		0.325	
Conventional initiating zone module - 4 inch mount (CIZM-4) *Note 1		0.325		1.000	
Miniature contact module (MCM)		0.325		0.325	
Single contact module - 4 inch mount (SCM-4)		0.325		1.000	
Dual contact module - 4 inch mount (DCM-4)		0.325		1.000	
Monitored output module - 4 inch mount (MOM-4) *Note 2		0.325		1.000	
Twin relay module - 4 inch mount (TRM-4)		0.325		1.000	
Short circuit isolator (SCI)		0.325		2.34	
Analog sounder base (ASB) *Note 3		0.325		0.325	
Analog relay base (ARB) *Note 4		0.325		0.325	
Isolator base (AIB)		0.325		2.34	
SLC alarm LED Current	n/a	n/a		n/a	27.0
		<b>SLC Standby Current</b>		<b>SLC Alarm Current</b>	

\* Note 1: CIZM requires 24VDC power source. Standby current Class A = 4.90 mA, Class B (8.5 mA). Alarm Current = 50.0 mA

\* Note 2: MOM requires 24VDC power source. Standby current = 1.60 mA. Alarm Current = 1.60 mA

\* Note 3: ASB requires 24VDC power source. Standby current = 5 mA. Alarm Current = 100 mA

\* Note 4: ARB requires 24VDC power source. Standby current = 5 mA. Alarm Current = 50 mA

## 10. Installation Notes

Circuit board assembly is mounted in the cabinet using nine (9) fasteners as shown in the illustration below.

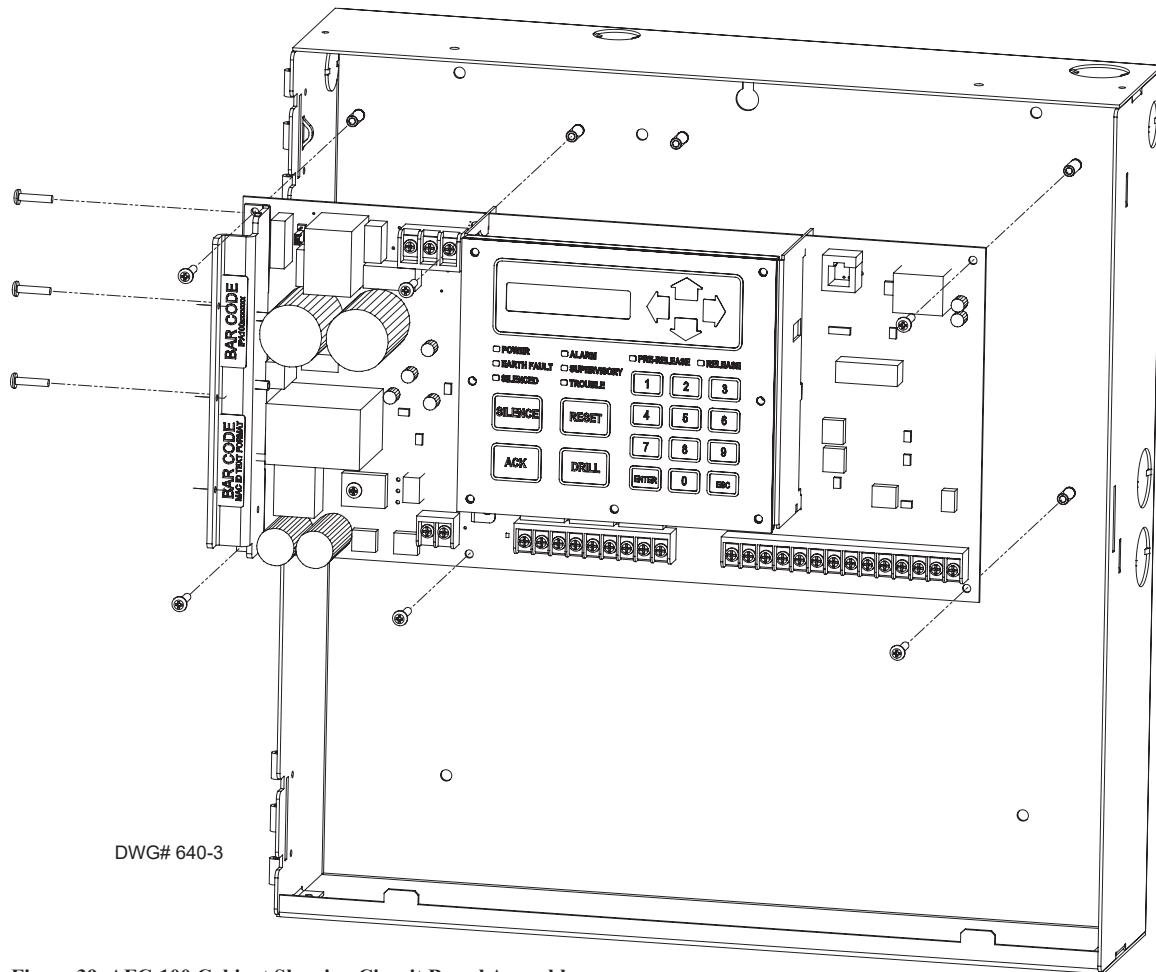

Figure 39. AFC-100 Cabinet Showing Circuit Board Assembly